

# CFD Simulations of Wind Turbines

Krzysztof Tesch

Gdansk University of Technology

# Introduction

**Introduction**

Classification

Coefficients

HAWT

VAWT

Unconventional

- Horizontal Axis Wind Turbines (HAWT)
  - ◆ One-, two-, three-bladed
  - ◆ Multi-bladed
  - ◆ Archimedes
- Vertical Axis Wind Turbines (VAWT)
  - ◆ Savonius
  - ◆ Darrieus
  - ◆ Combined
  - ◆ Banki–Michell
  - ◆ Piskorz
- Unconventional

Introduction

**Classification**

Coefficients

HAWT

VAWT

Unconventional

- Torque coefficient

$$C_T = \frac{T}{\frac{1}{4}\rho U^2 DA}$$

- Power coefficient

$$C_P = \frac{\omega T}{\frac{1}{2}\rho U^3 A}$$

- Tip speed ratio

$$\lambda = \frac{\omega R}{U} = \frac{\omega D}{2U} = \frac{C_P}{C_T}$$

Introduction

Classification

**Coefficients**

HAWT

VAWT

Unconventional

# Averaged coefficients

- Torque coefficient

$$\bar{C}_T = \frac{\bar{T}}{\frac{1}{4}\rho U^2 DA}$$

- Power coefficient

$$\bar{C}_P = \frac{\omega \bar{T}}{\frac{1}{2}\rho U^3 A}$$

where  $\tau = n \Delta t$  (e.g. one revolution,  $\Delta t = \text{const}$ )

$$\bar{T} = \frac{1}{\tau} \int_t^{t+\tau} T(t) dt \approx \frac{1}{\tau} \sum_{i=1}^n T_i \Delta t = \frac{1}{n} \sum_{i=1}^n T_i$$

[Introduction](#)

[Classification](#)

[Coefficients](#)

[HAWT](#)

[VAWT](#)

[Unconventional](#)

# Active area

$$A = \begin{cases} \frac{1}{4}\pi D^2, & \text{HAWT,} \\ DH, & \text{VAWT} \end{cases}$$

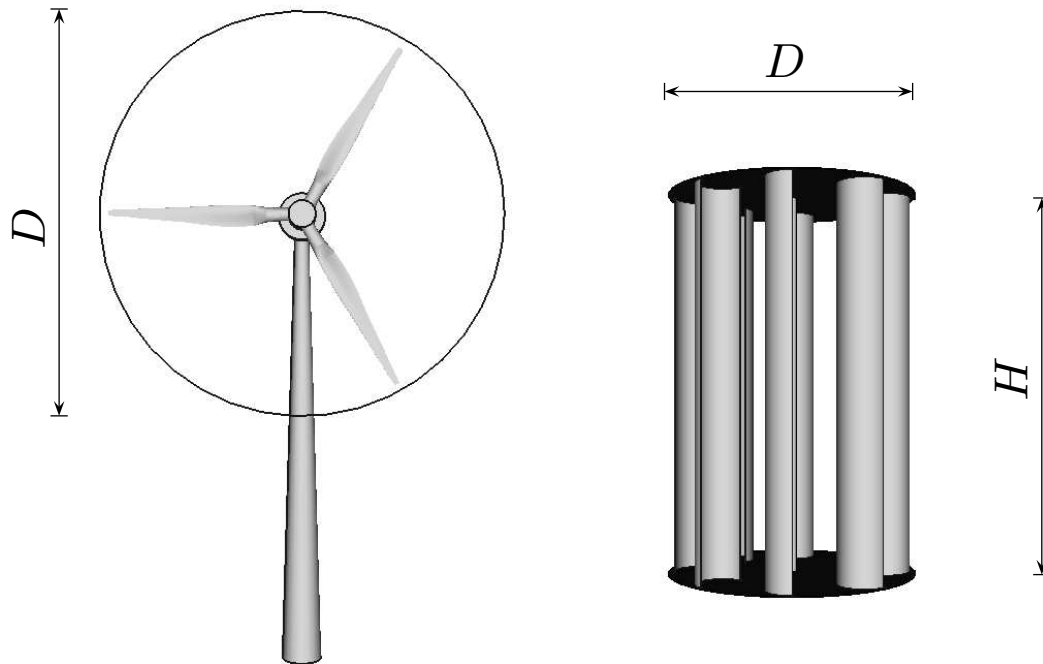

Introduction

Classification

**Coefficients**

HAWT

VAWT

Unconventional

# HAWT

Introduction

**HAWT**

Three-bladed

Multi-bladed

Archimedes

VAWT

Unconventional

# One-, two-, three-bladed

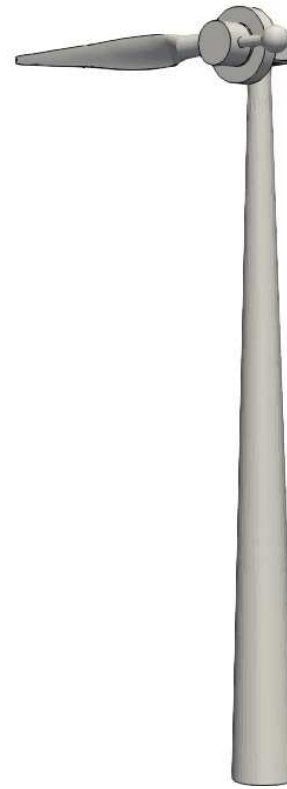
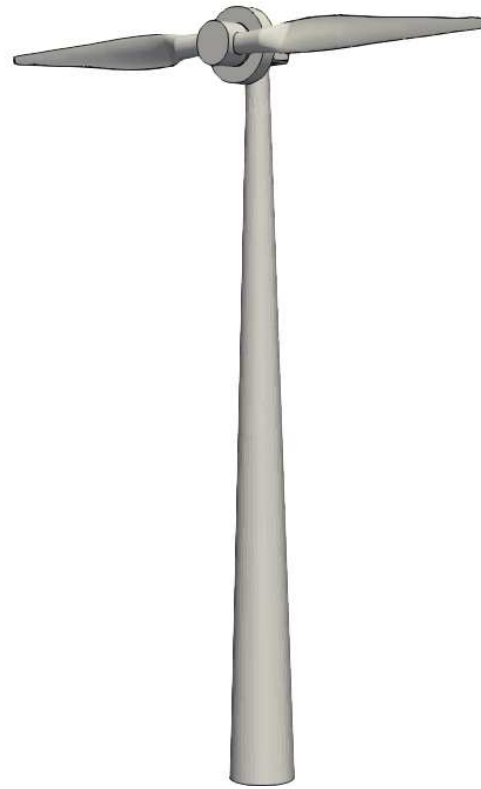

Introduction

HAWT

Three-bladed

Multi-bladed

Archimedes

VAWT

Unconventional



# Three-bladed HAWT

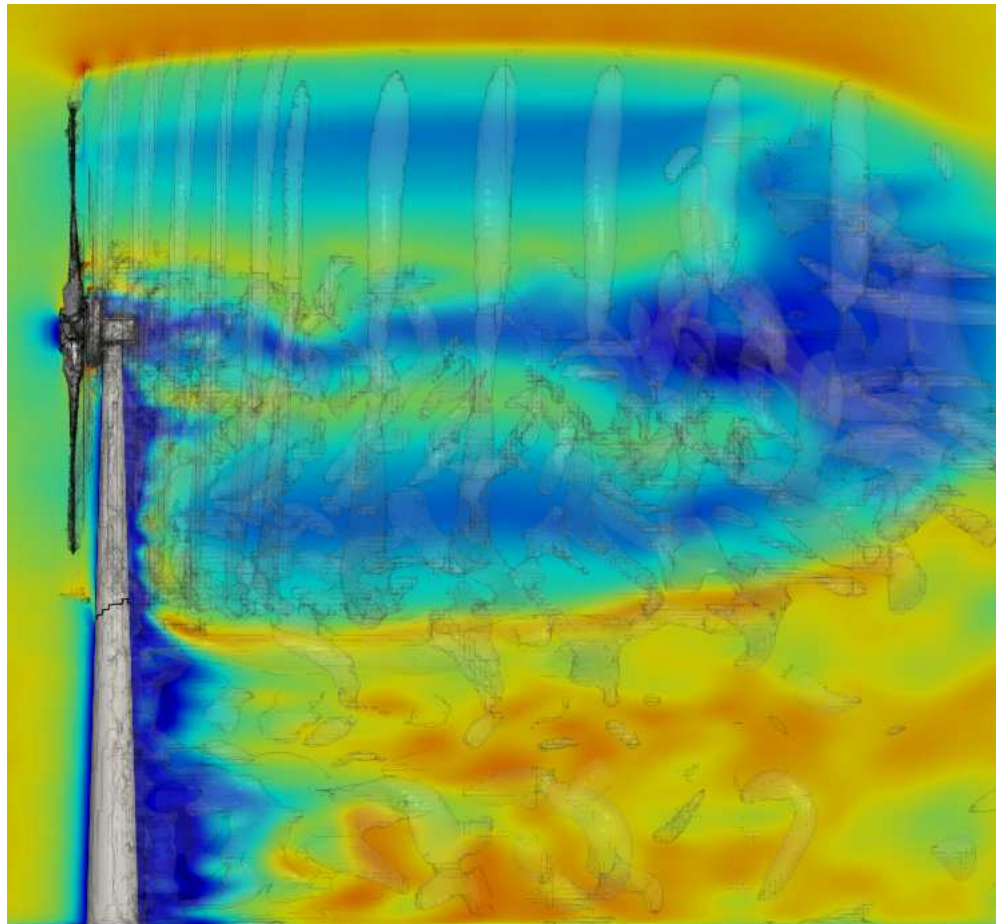

$t = 60.00$  s  
 $U = 8$  m/s  
 $n = 10$  rpm

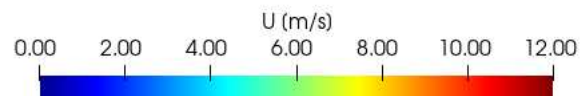

Introduction

HAWT

**Three-bladed**

Multi-bladed

Archimedes

VAWT

Unconventional

# Three-bladed HAWT

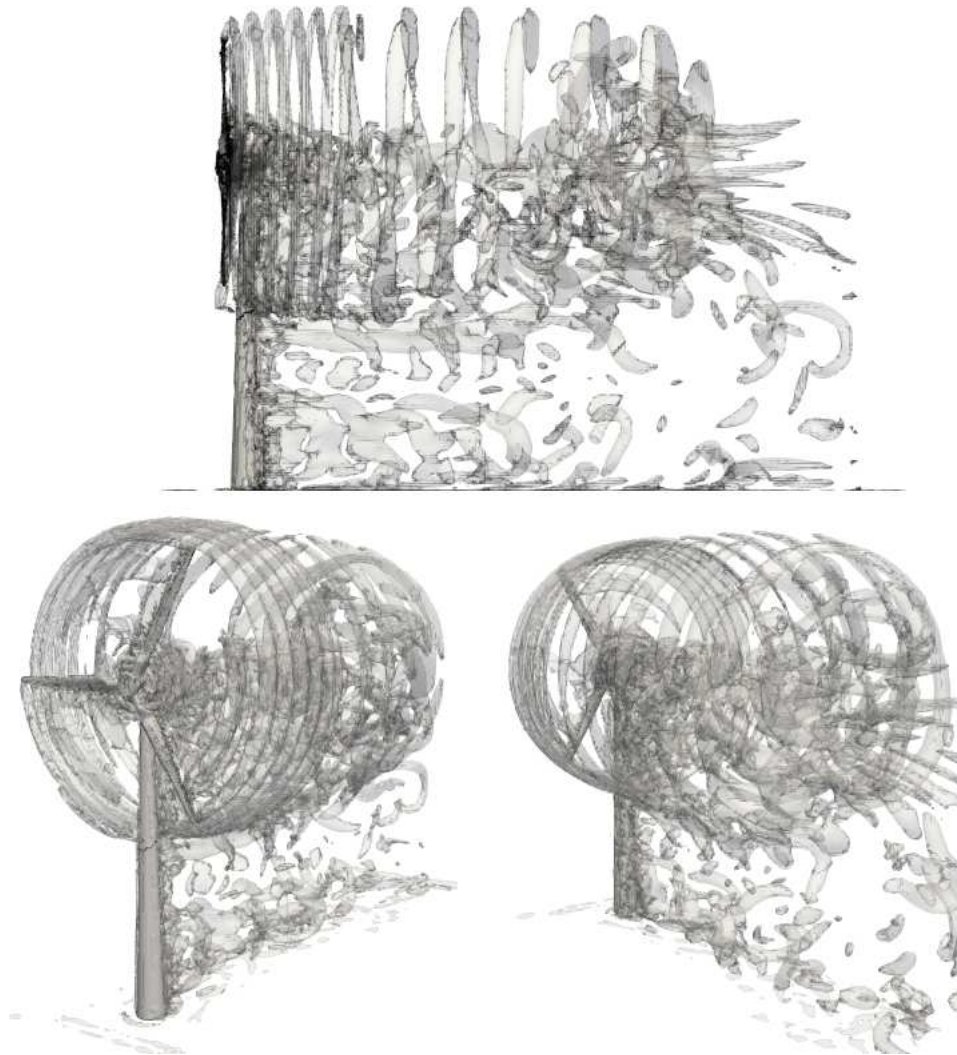

Introduction

HAWT

**Three-bladed**

Multi-bladed

Archimedes

VAWT

Unconventional

# Three-bladed HAWT

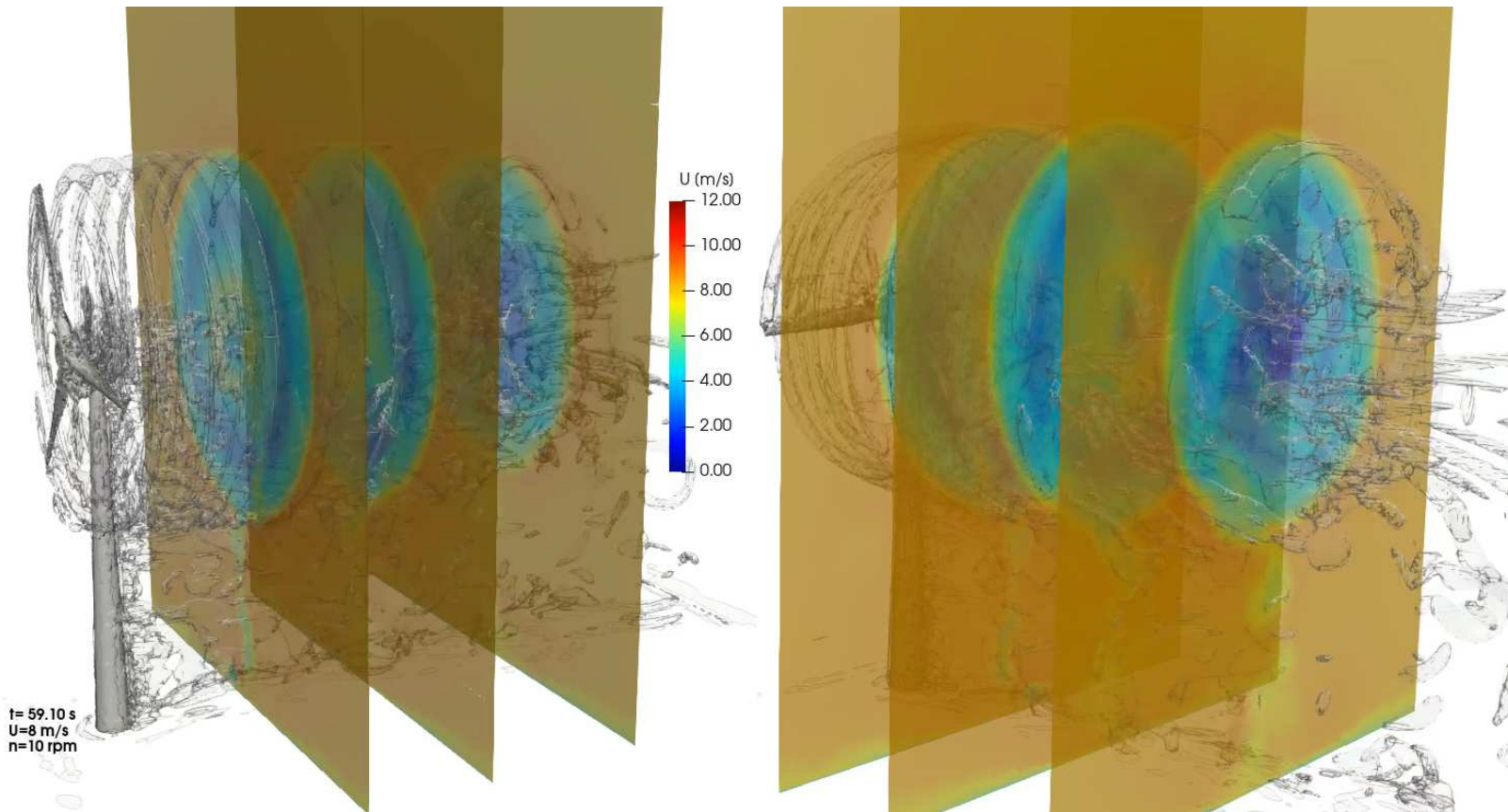

Introduction

HAWT

**Three-bladed**

Multi-bladed

Archimedes

VAWT

Unconventional

# Two-bladed HAWT

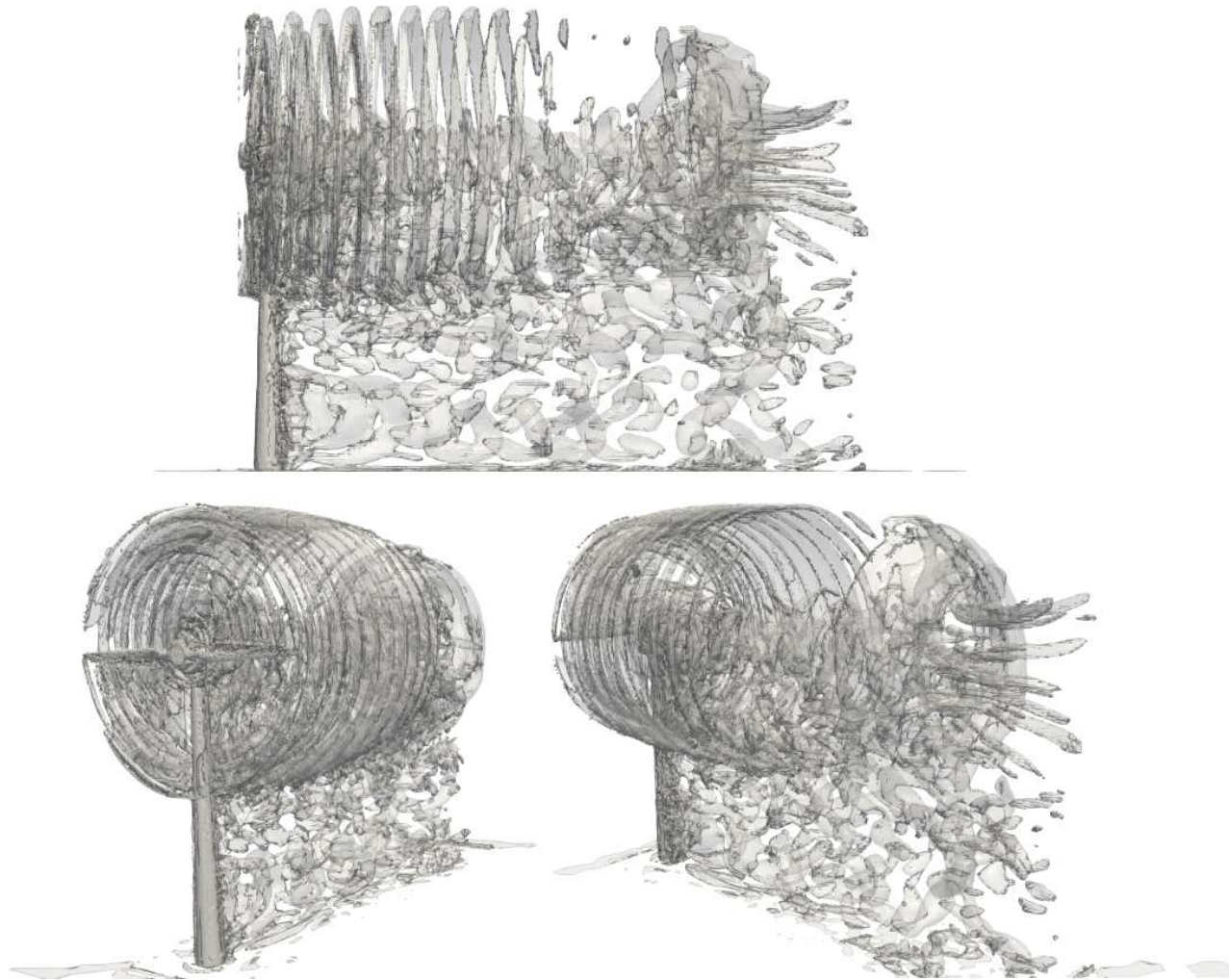

Introduction

HAWT

**Three-bladed**

Multi-bladed

Archimedes

VAWT

Unconventional

# One-bladed HAWT

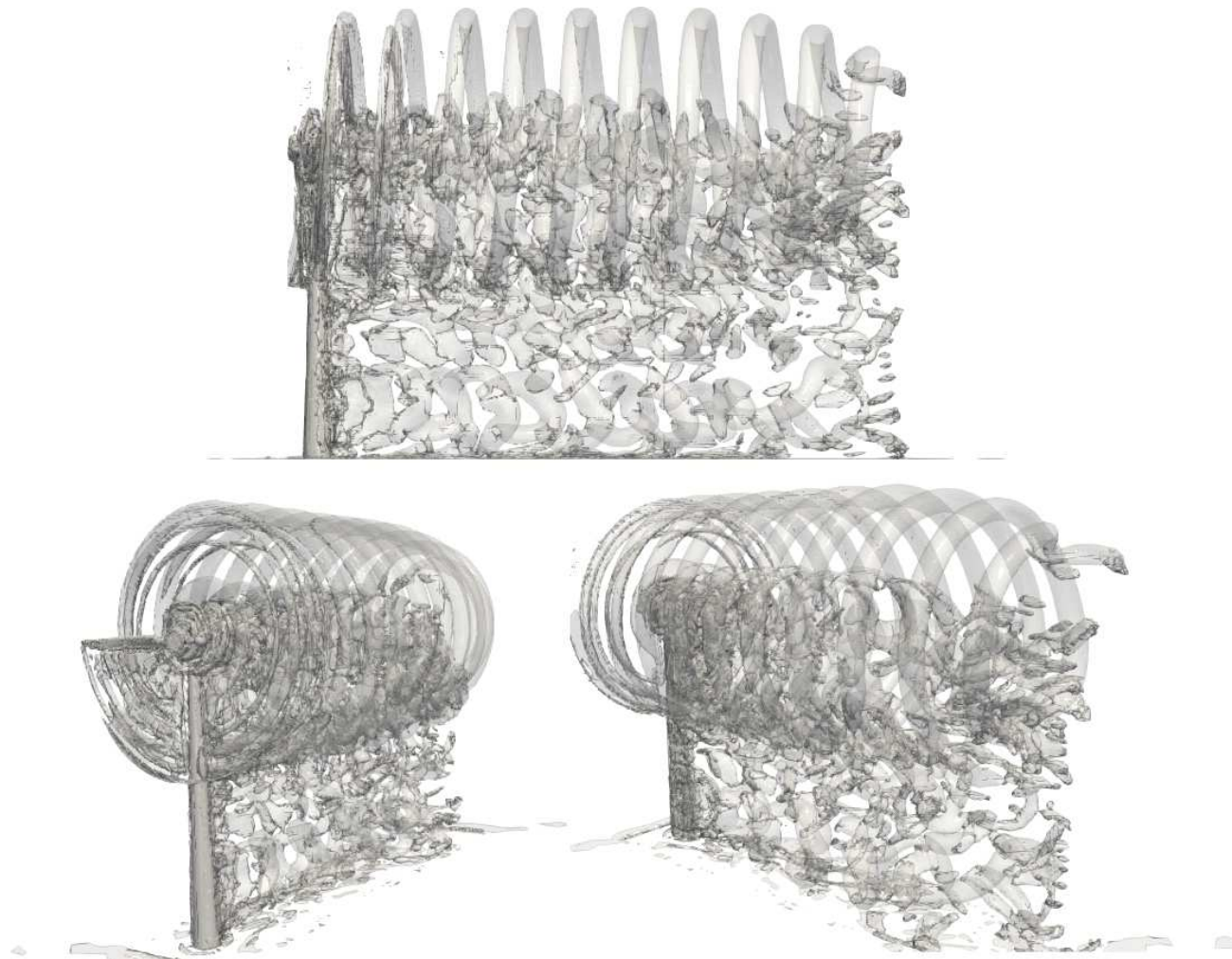

Introduction

HAWT

**Three-bladed**

Multi-bladed

Archimedes

VAWT

Unconventional

# One-, two-, three-bladed



Introduction

HAWT

**Three-bladed**

Multi-bladed

Archimedes

VAWT

Unconventional

# One-, two-, three-bladed

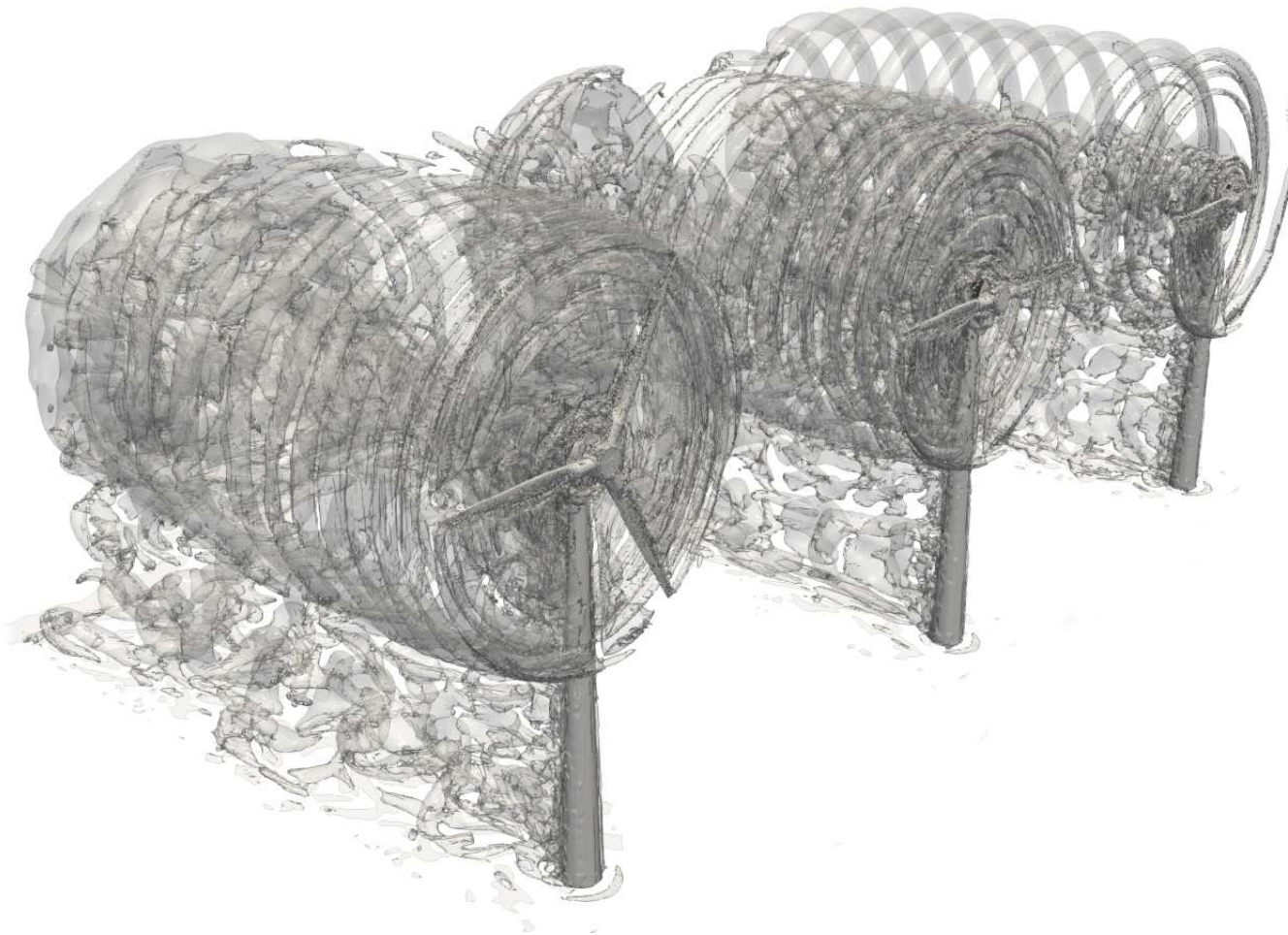

Introduction

HAWT

**Three-bladed**

Multi-bladed

Archimedes

VAWT

Unconventional

# Multi-bladed

Introduction

HAWT

Three-bladed

**Multi-bladed**

Archimedes

VAWT

Unconventional



# Archimedes

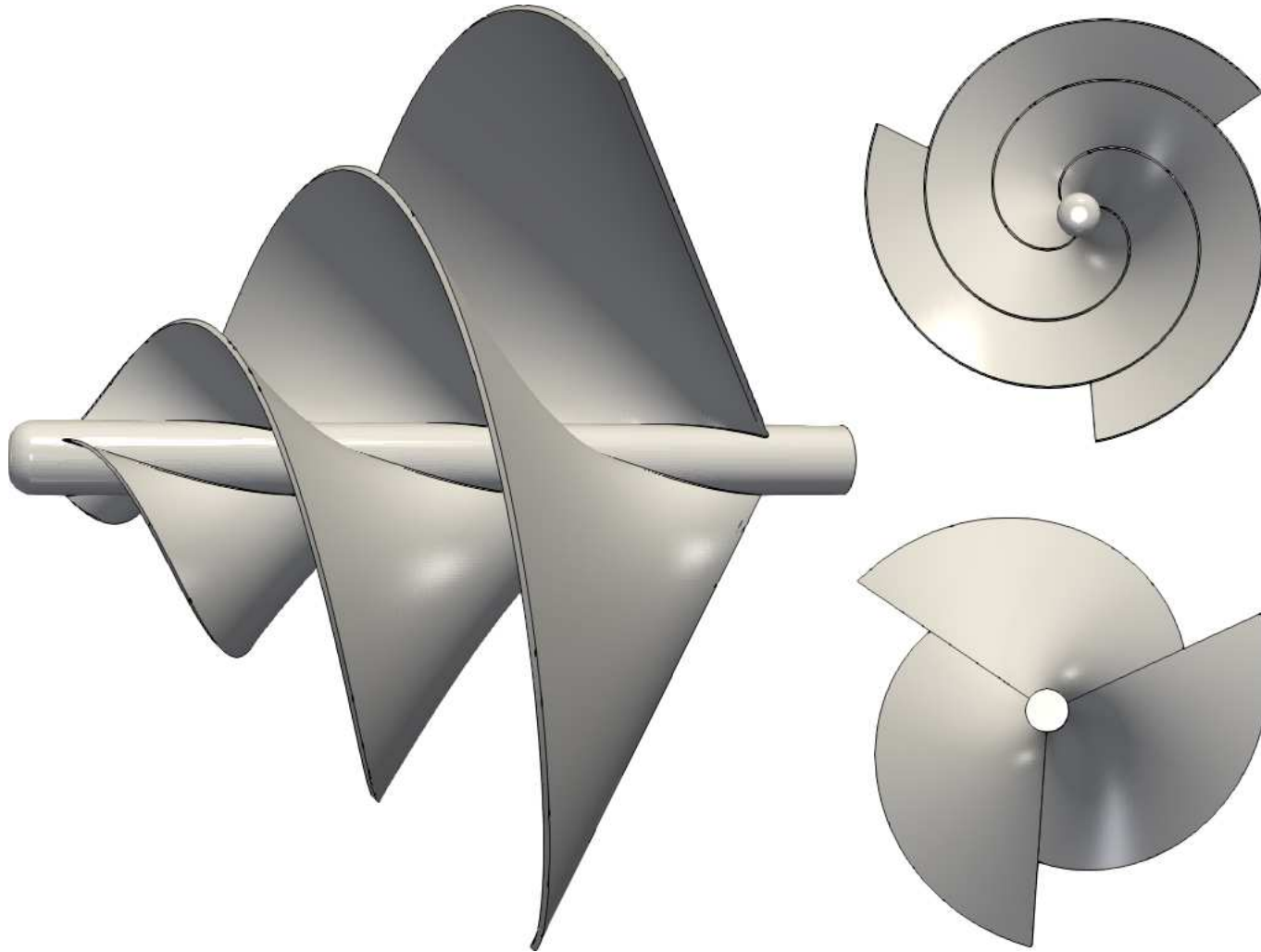

Introduction

HAWT

Three-bladed

Multi-bladed

**Archimedes**

VAWT

Unconventional

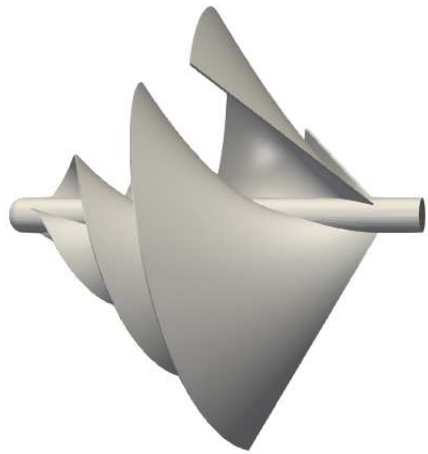

Time: 5.00 s

Introduction

HAWT

Three-bladed

Multi-bladed

**Archimedes**

VAWT

Unconventional

# Archimedes

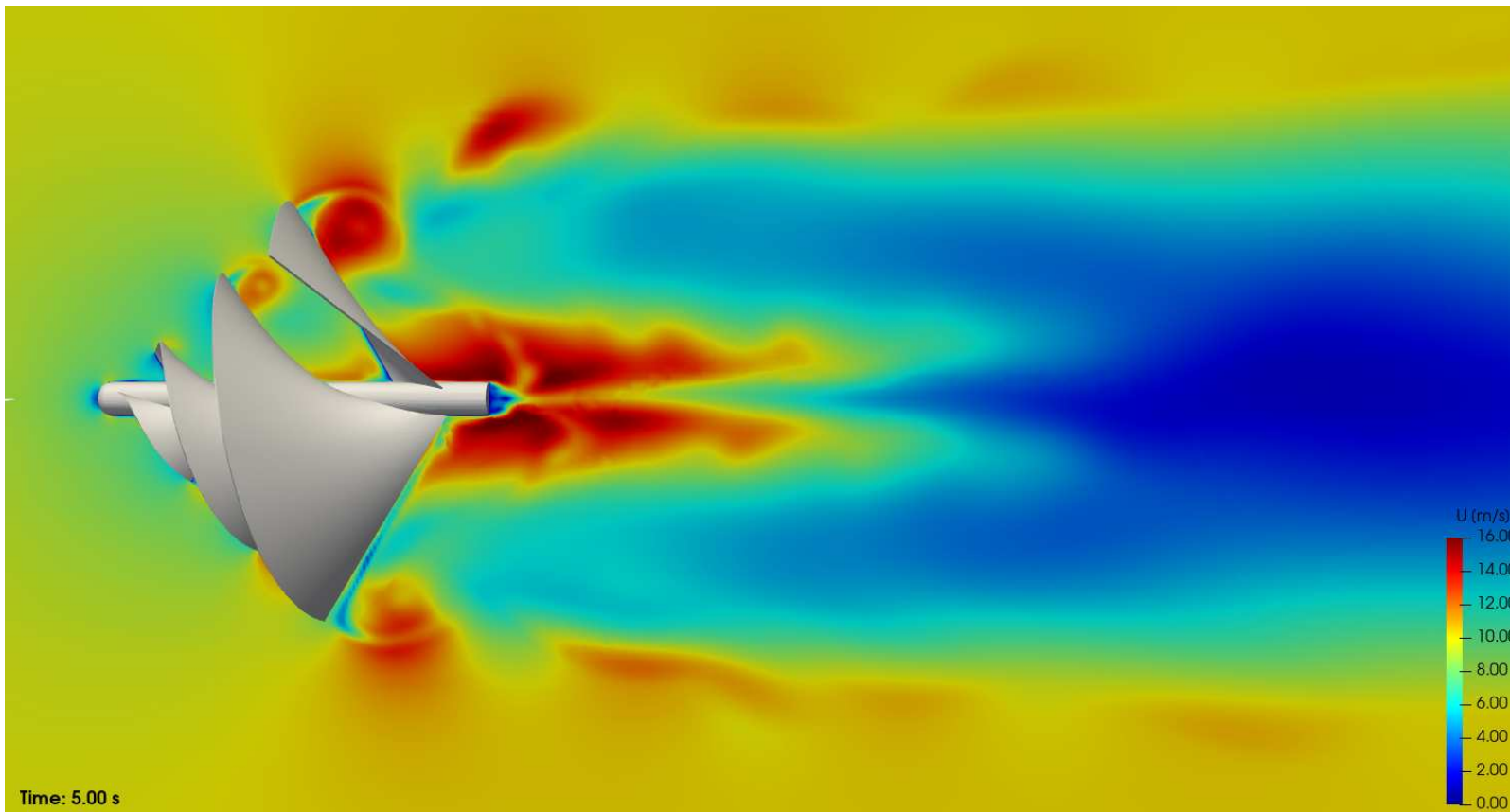

Introduction

HAWT

Three-bladed

Multi-bladed

**Archimedes**

VAWT

Unconventional

# Archimedes

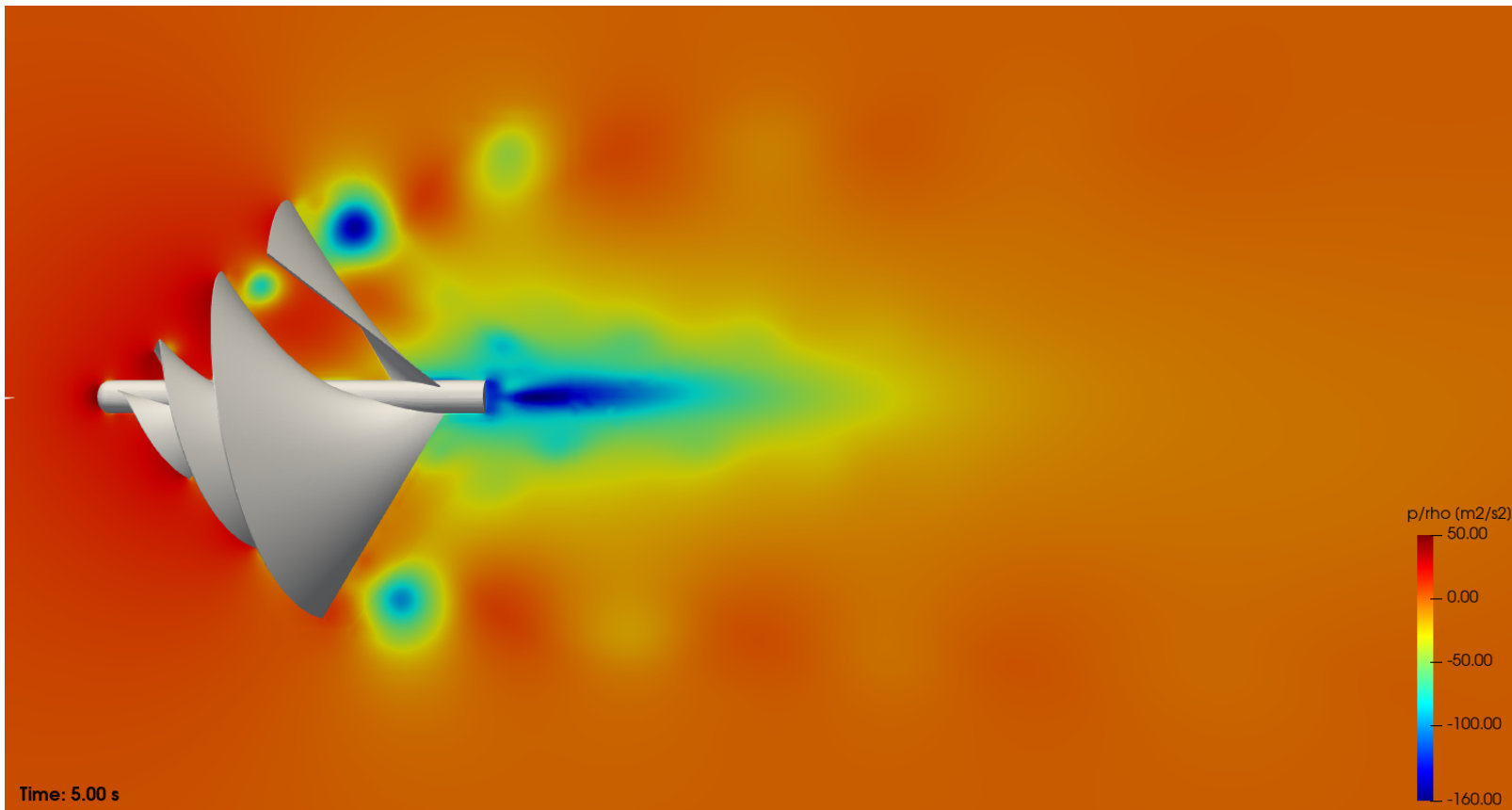

Introduction

HAWT

Three-bladed

Multi-bladed

**Archimedes**

VAWT

Unconventional

# Archimedes

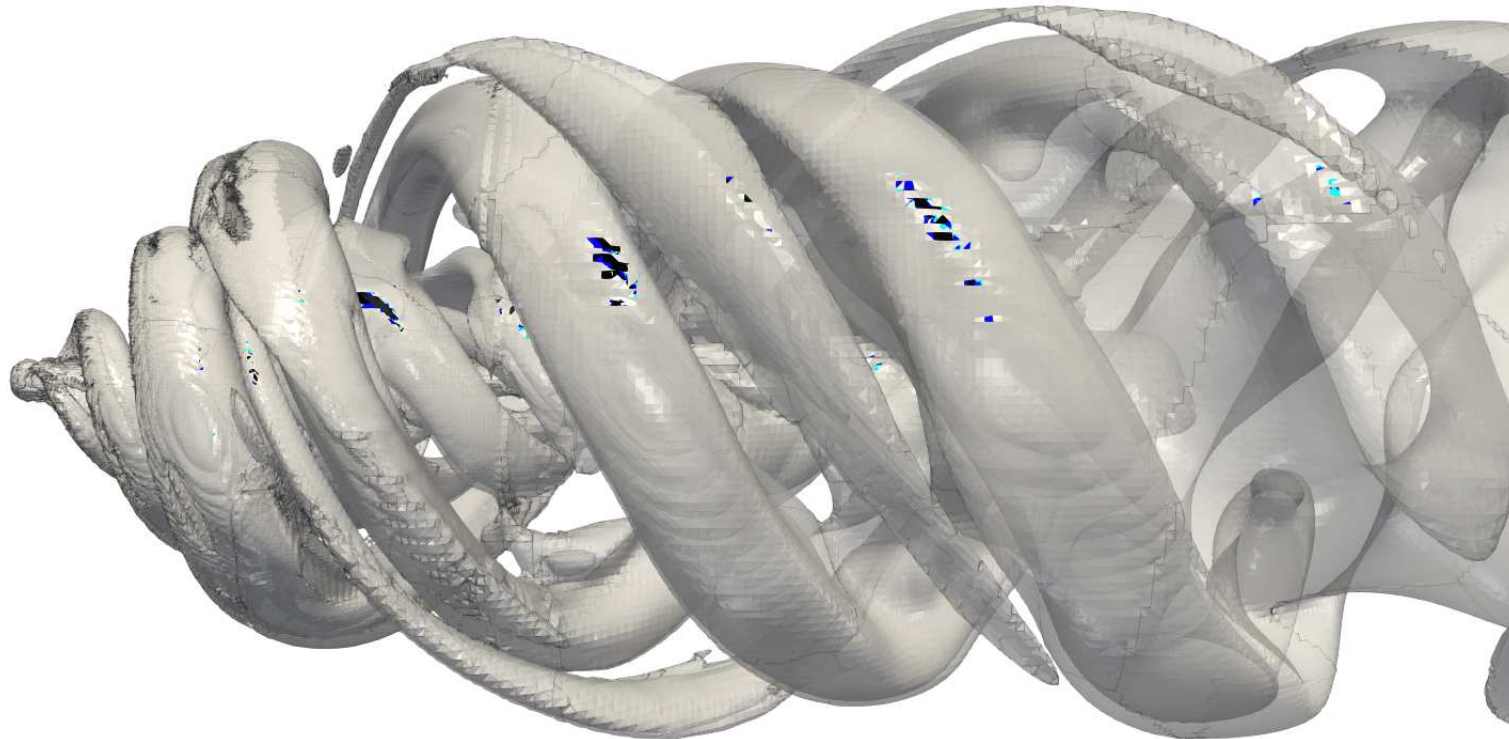

Time: 5.00 s

Introduction

HAWT

Three-bladed

Multi-bladed

**Archimedes**

VAWT

Unconventional

# VAWT

Introduction

HAWT

**VAWT**

Savonius

Darrieus

Combined

Banki–Michell

Piskorz

Unconventional

# Savonius

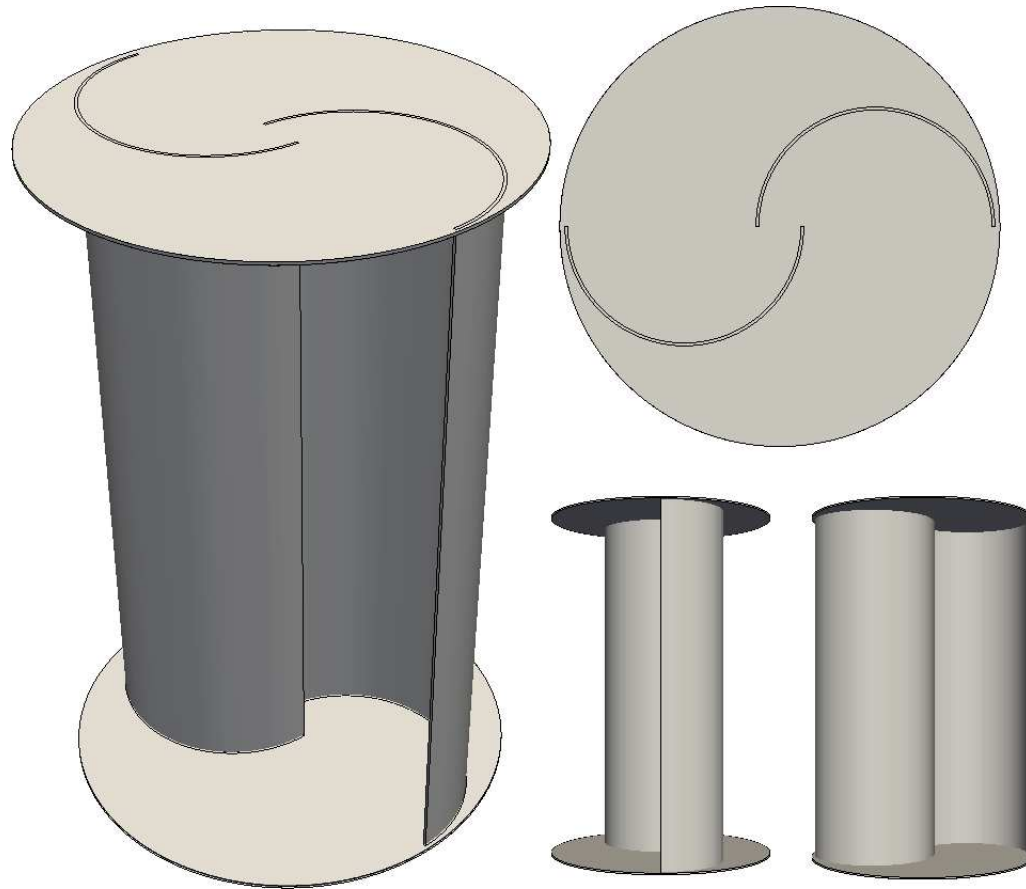

Introduction

HAWT

VAWT

**Savonius**

Darrieus

Combined

Banki–Michell

Piskorz

Unconventional

- Invented by the Finnish engineer S.J. Savonius in 1922
- Already known in XVII century book *Machinae novae*
- One of the simplest (cheapest) turbines
- Low noise
- Low efficiency
- No pointing mechanism required
- Self-starting
- High torque and low rpm
- Helical blades generate smooth torque

Introduction

HAWT

VAWT

**Savonius**

Darrieus

Combined

Banki–Michell

Piskorz

Unconventional



# Savonius

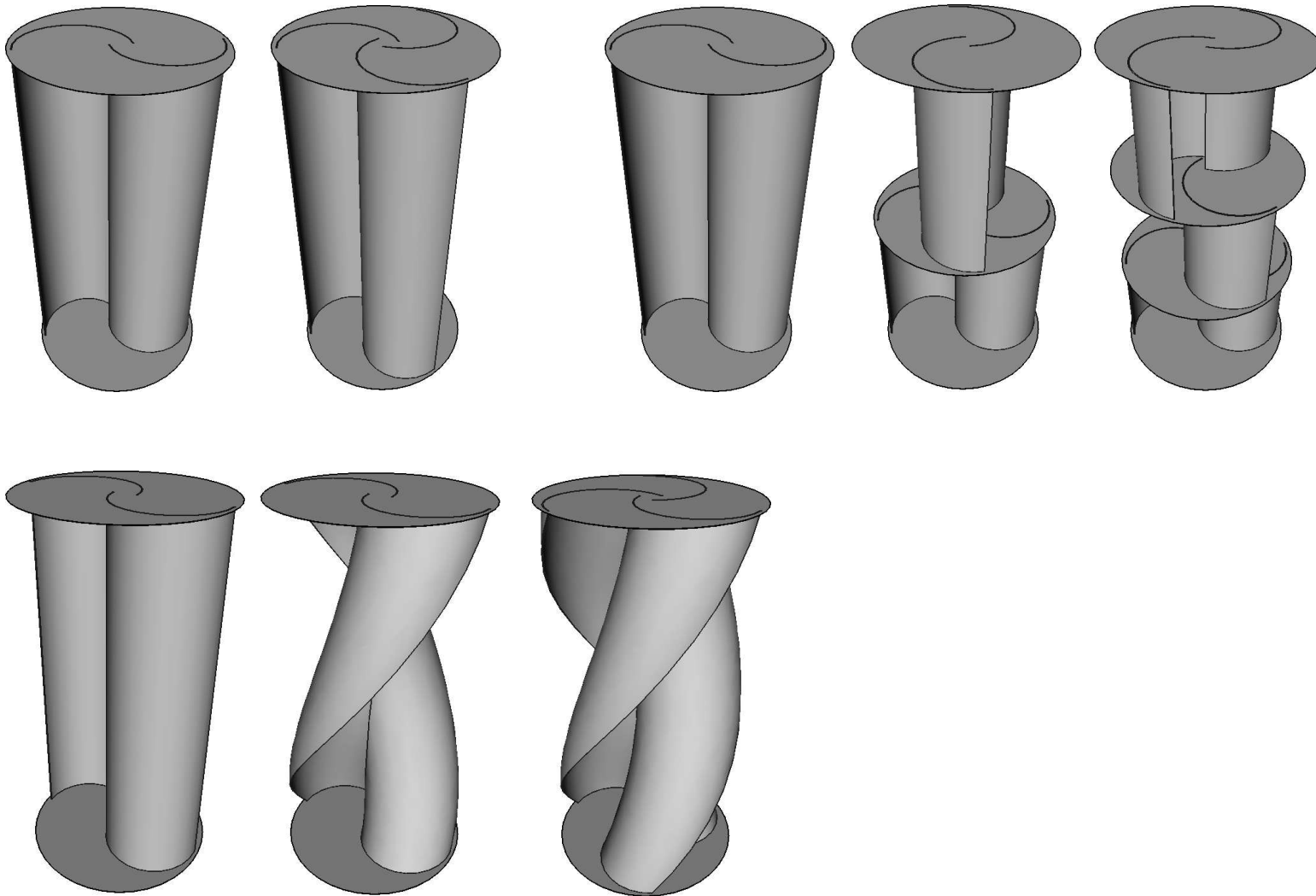

Introduction

HAWT

VAWT

**Savonius**

Darrieus

Combined

Banki–Michell

Piskorz

Unconventional

# Savonius

Introduction

HAWT

VAWT

**Savonius**

Darrieus

Combined

Banki–Michell

Piskorz

Unconventional

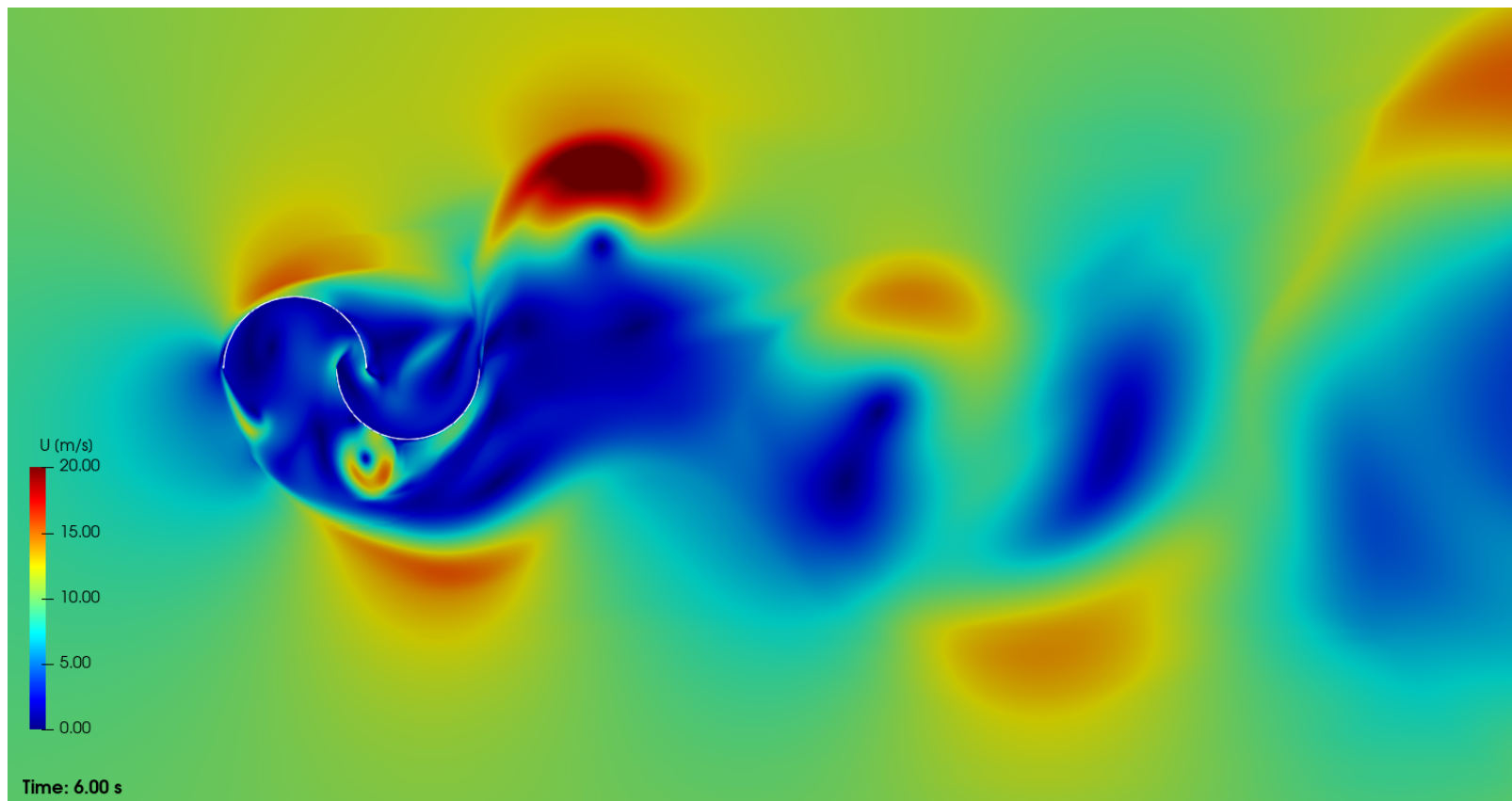

# 2D Savonius

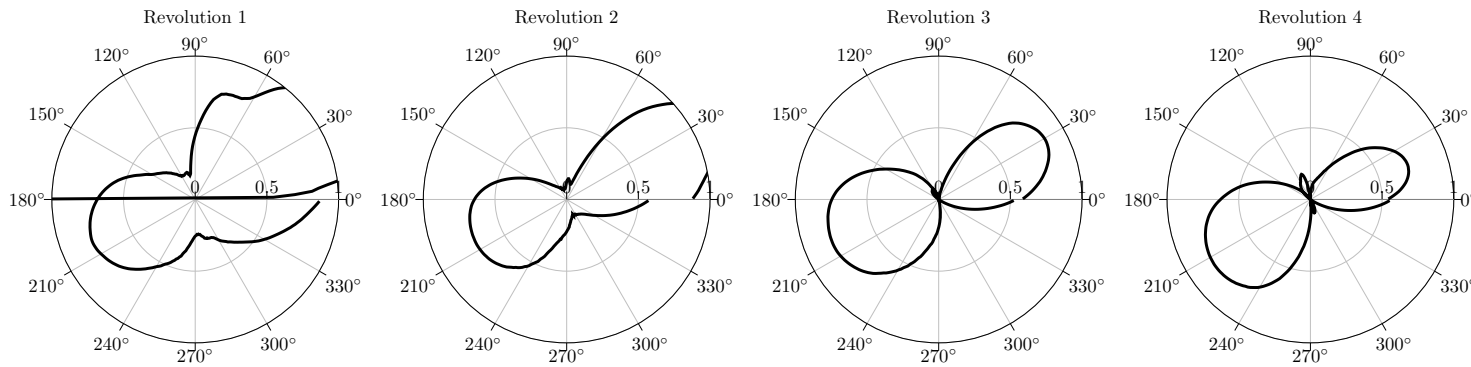
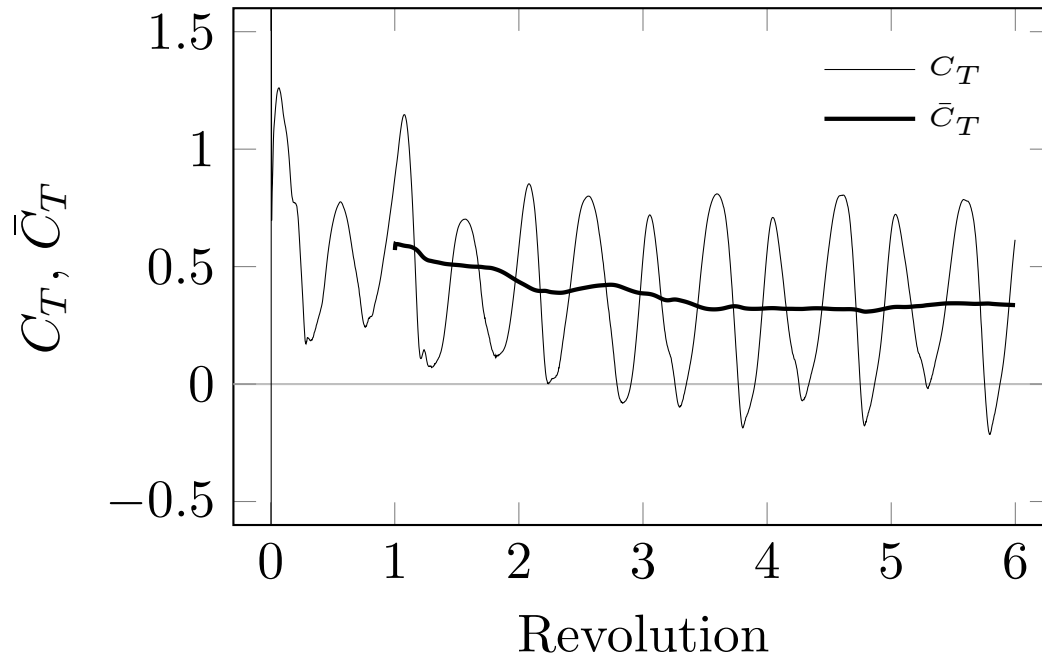

Introduction

HAWT

VAWT

**Savonius**

Darrieus

Combined

Banki–Michell

Piskorz

Unconventional

# 2D Savonius

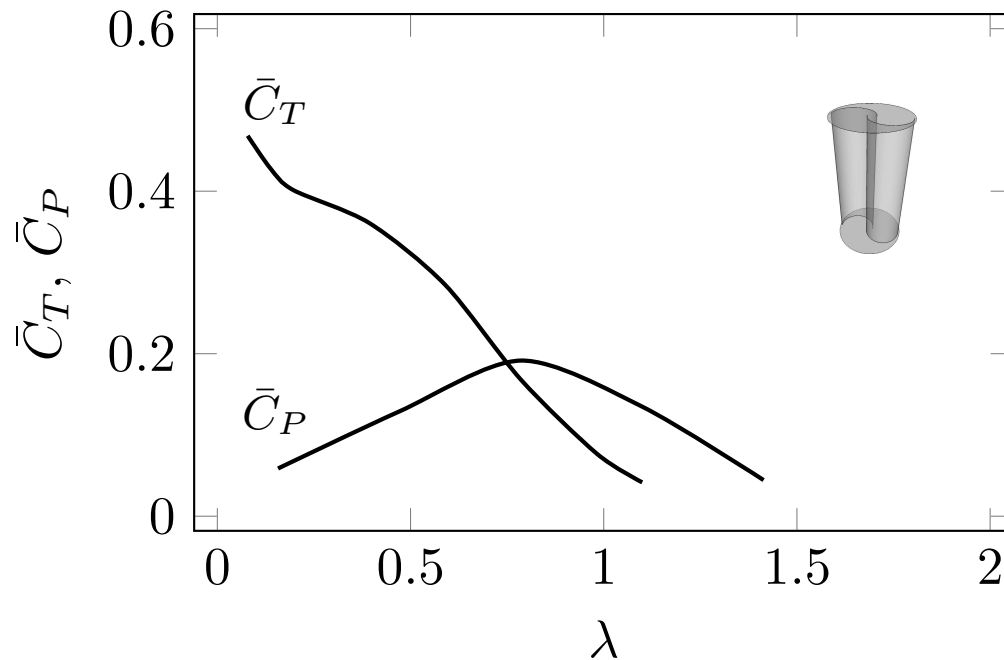

Introduction

HAWT

VAWT

**Savonius**

Darrieus

Combined

Banki-Michell

Piskorz

Unconventional

- Classic Darrieus
- H Darrieus
- Helical Darrieus

Introduction

HAWT

VAWT

Savonius

**Darrieus**

Combined

Banki–Michell

Piskorz

Unconventional

# Darrieus

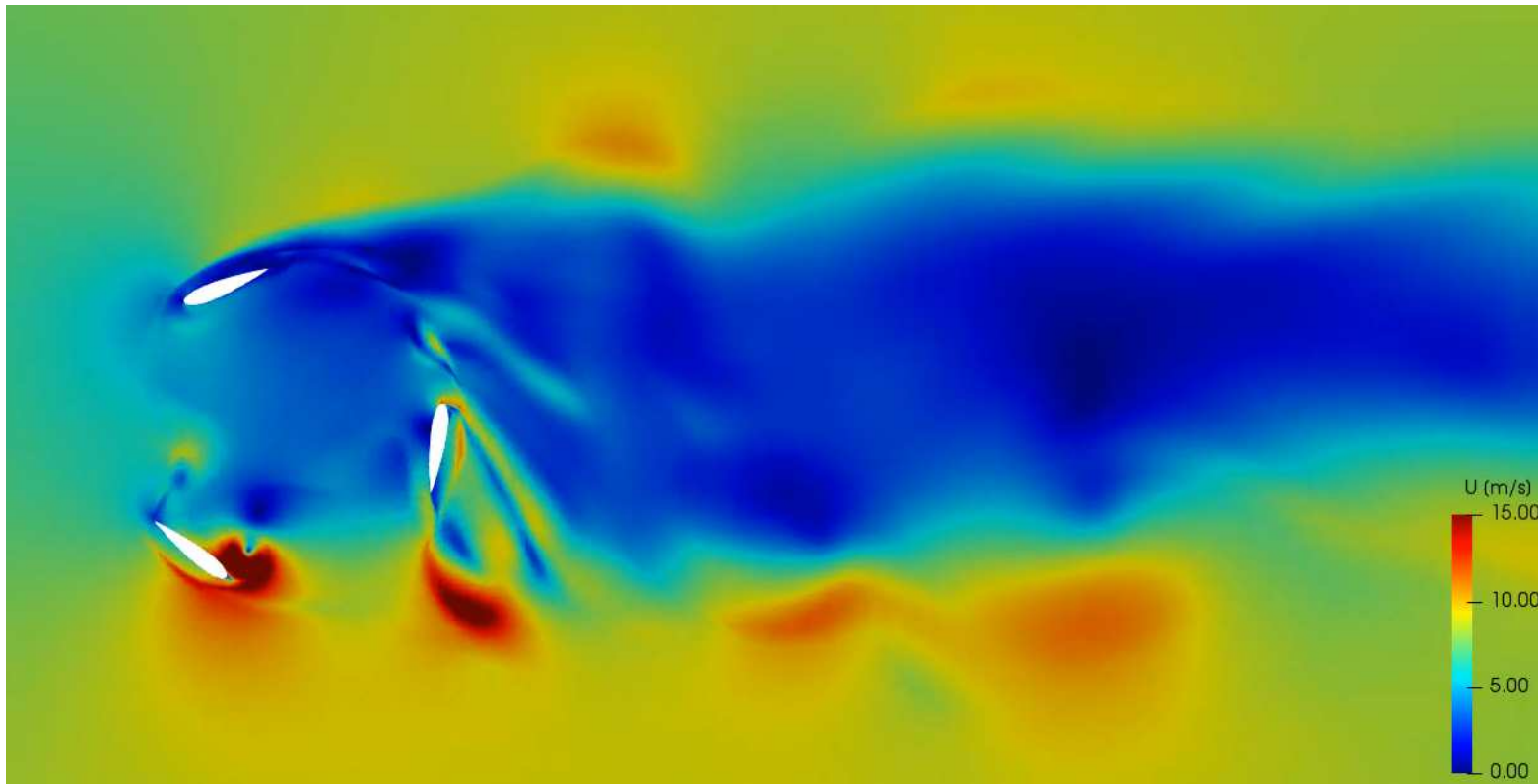

Introduction

HAWT

VAWT

Savonius

**Darrieus**

Combined

Banki–Michell

Piskorz

Unconventional

# Combined Savonius–Darrieus

Introduction

HAWT

VAWT

Savonius

Darrieus

**Combined**

Banki–Michell

Piskorz

Unconventional

# Banki–Michell

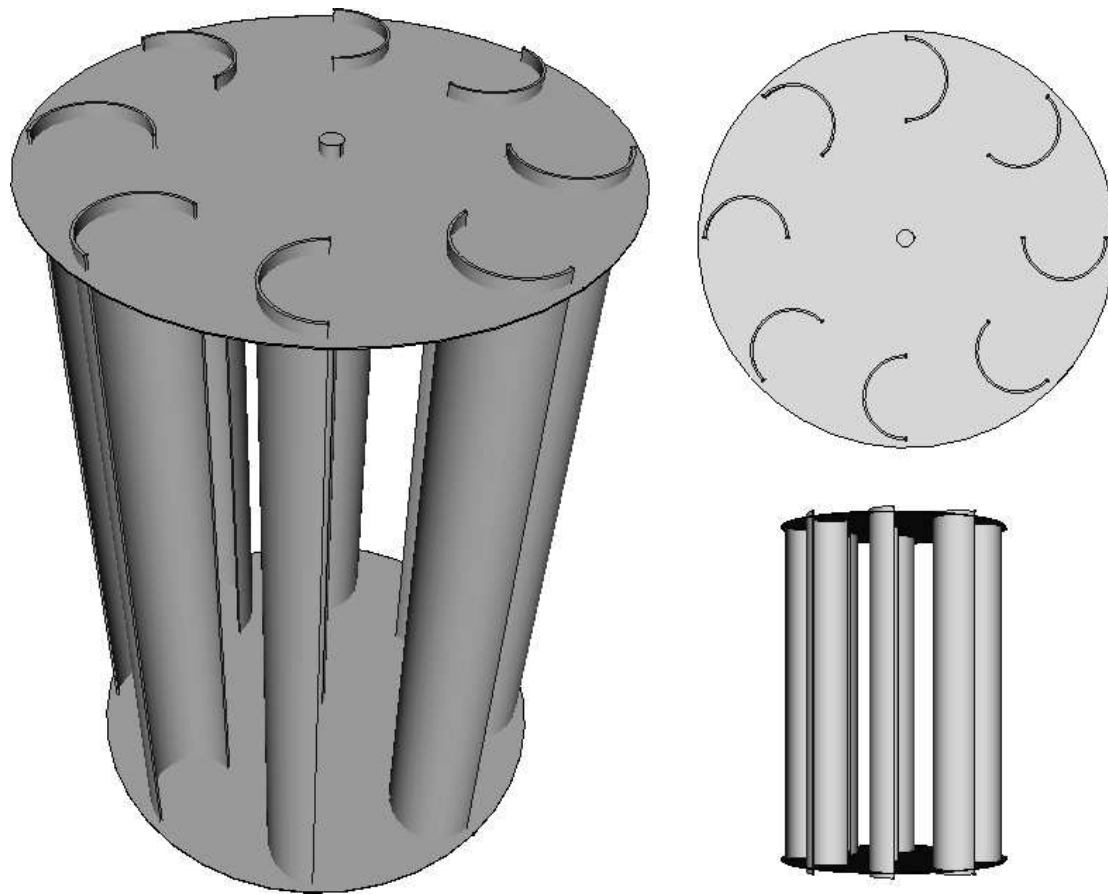

Introduction

HAWT

VAWT

Savonius

Darrieus

Combined

**Banki–Michell**

Piskorz

Unconventional



# Banki–Michell

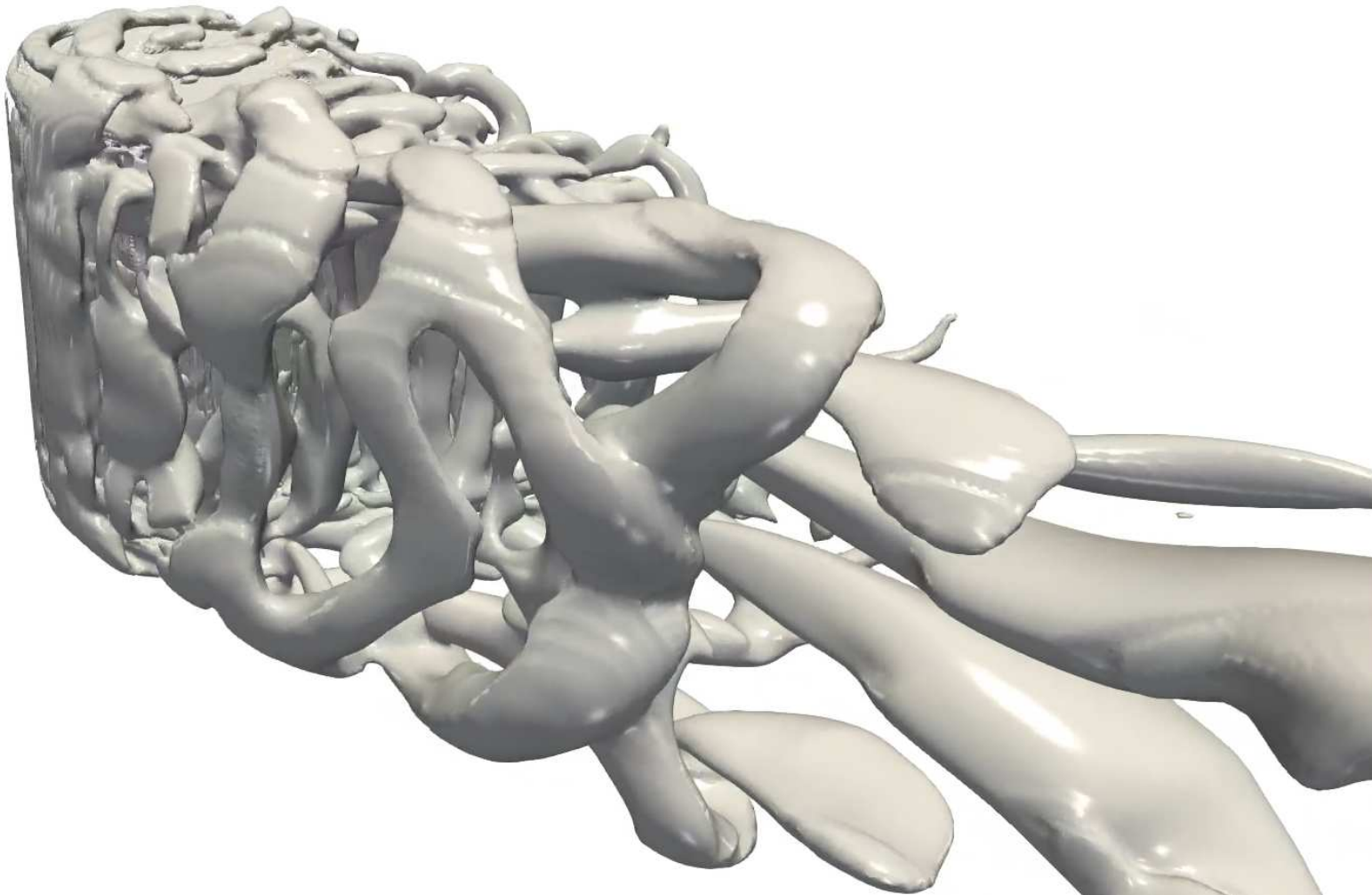

Introduction

HAWT

VAWT

Savonius

Darrieus

Combined

**Banki–Michell**

Piskorz

Unconventional

# Banki–Michell

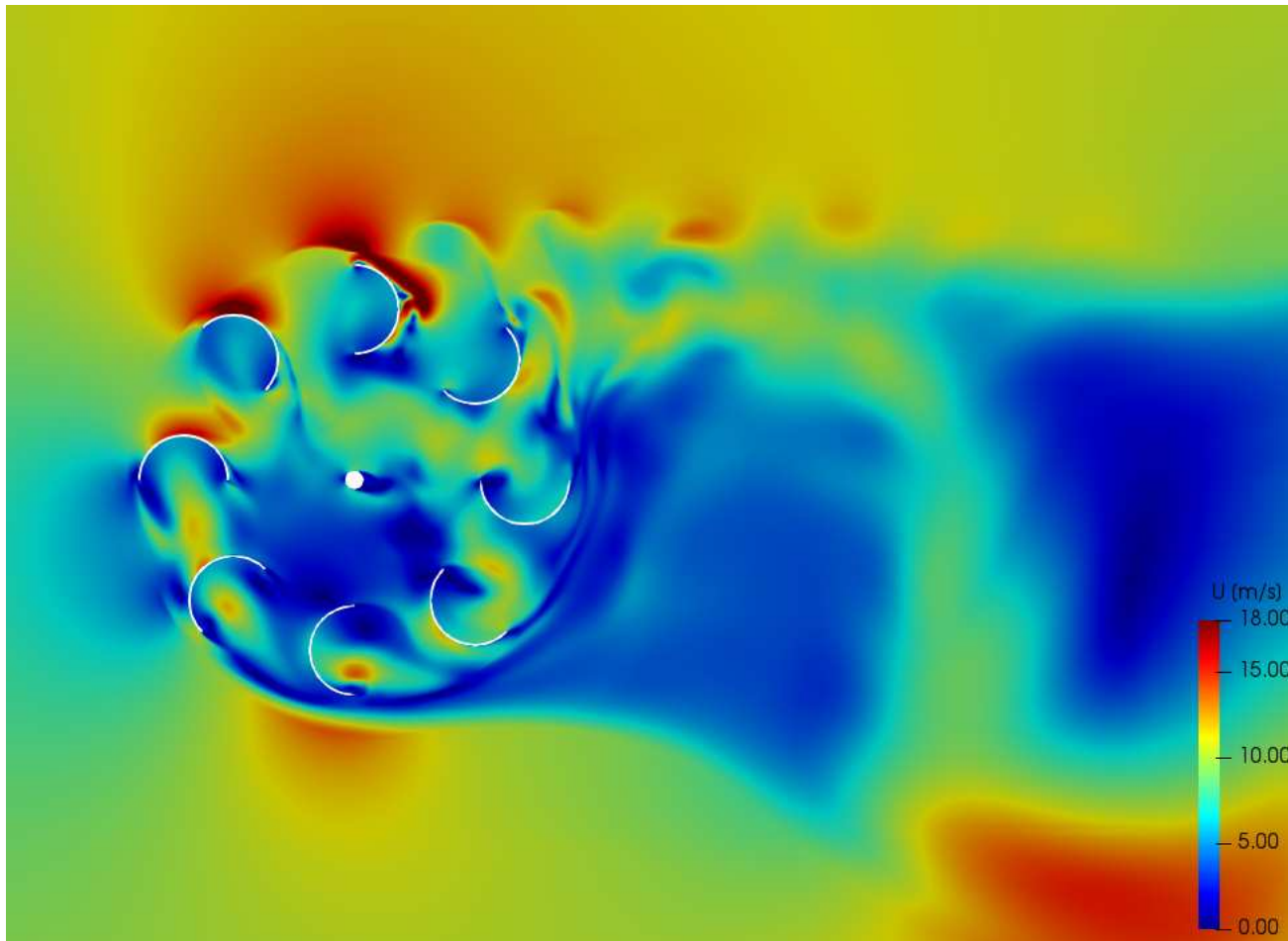

Introduction

HAWT

VAWT

Savonius

Darrieus

Combined

**Banki–Michell**

Piskorz

Unconventional

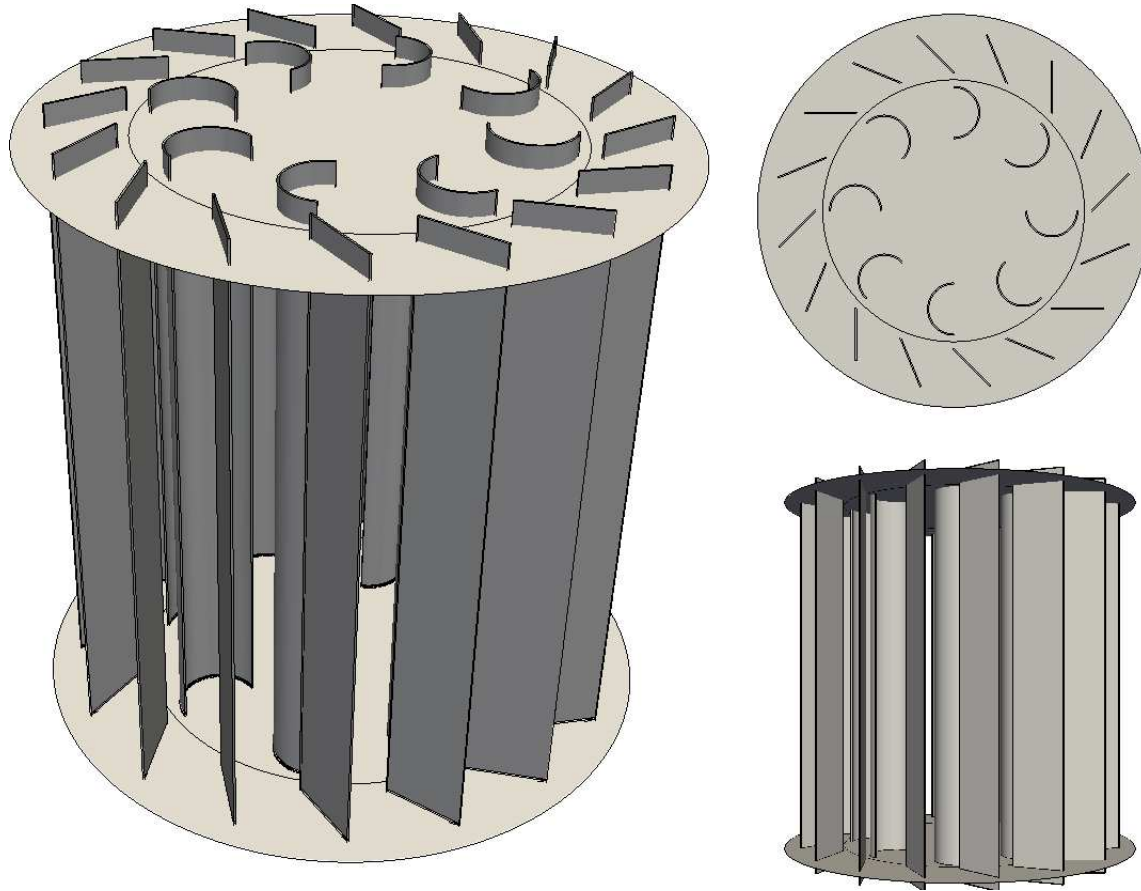

Introduction

HAWT

VAWT

Savonius

Darrieus

Combined

Banki-Michell

**Piskorz**

Unconventional

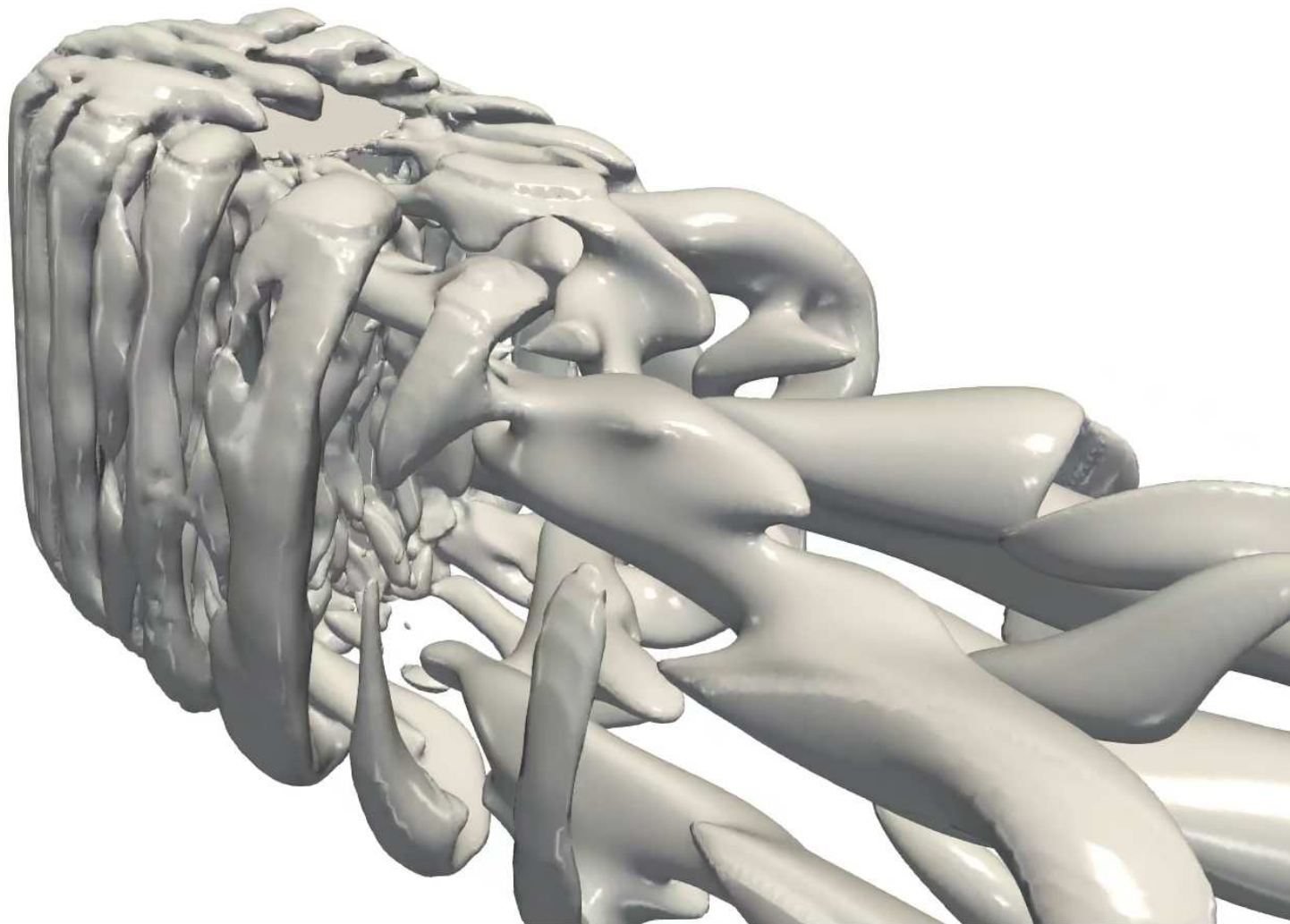

Introduction

HAWT

VAWT

Savonius

Darrieus

Combined

Banki–Michell

**Piskorz**

Unconventional

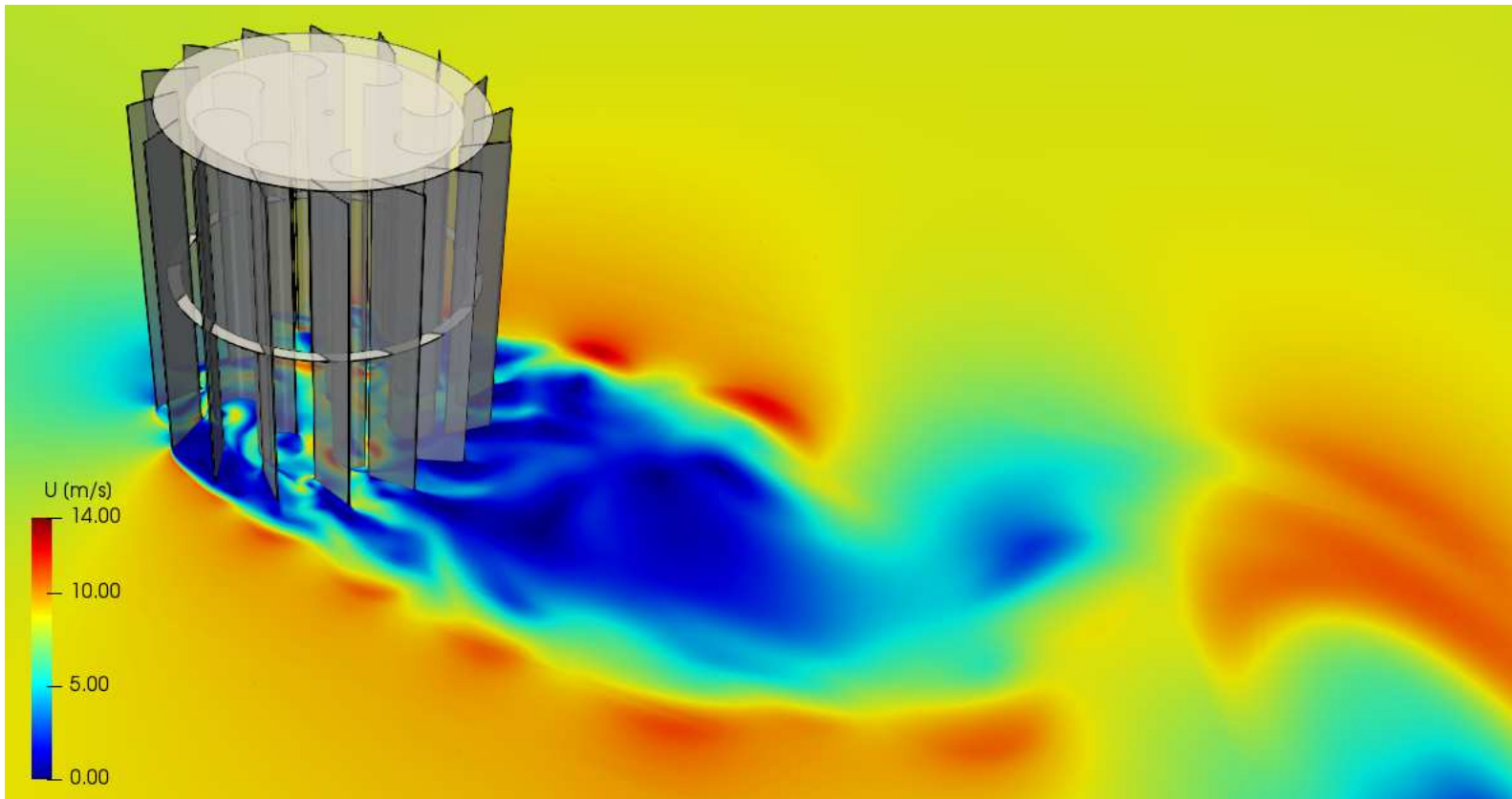

Introduction

HAWT

VAWT

Savonius

Darrieus

Combined

Banki-Michell

**Piskorz**

Unconventional

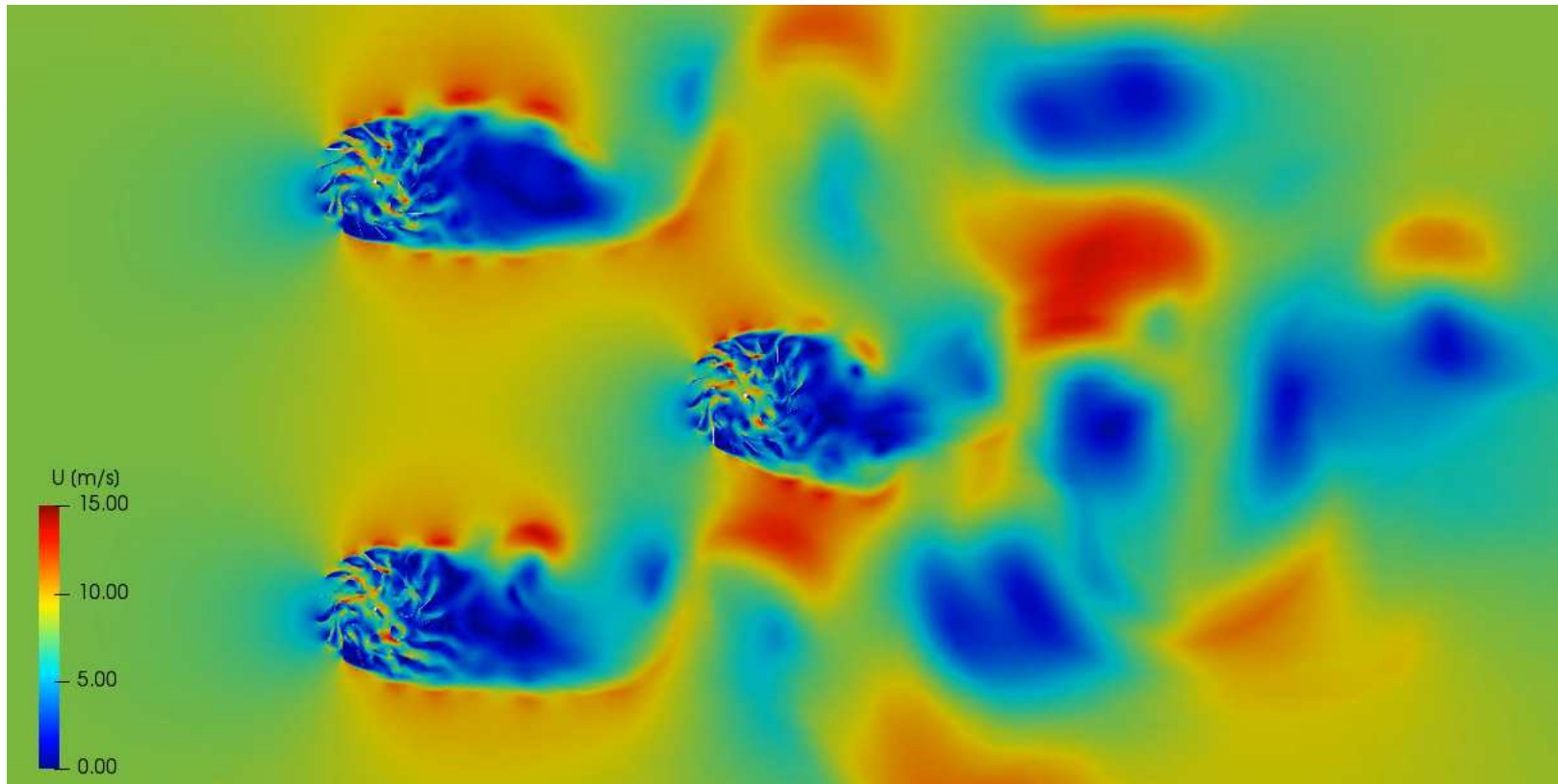

Introduction

HAWT

VAWT

Savonius

Darrieus

Combined

Banki-Michell

**Piskorz**

Unconventional

# Piskorz vs Banki–Michell

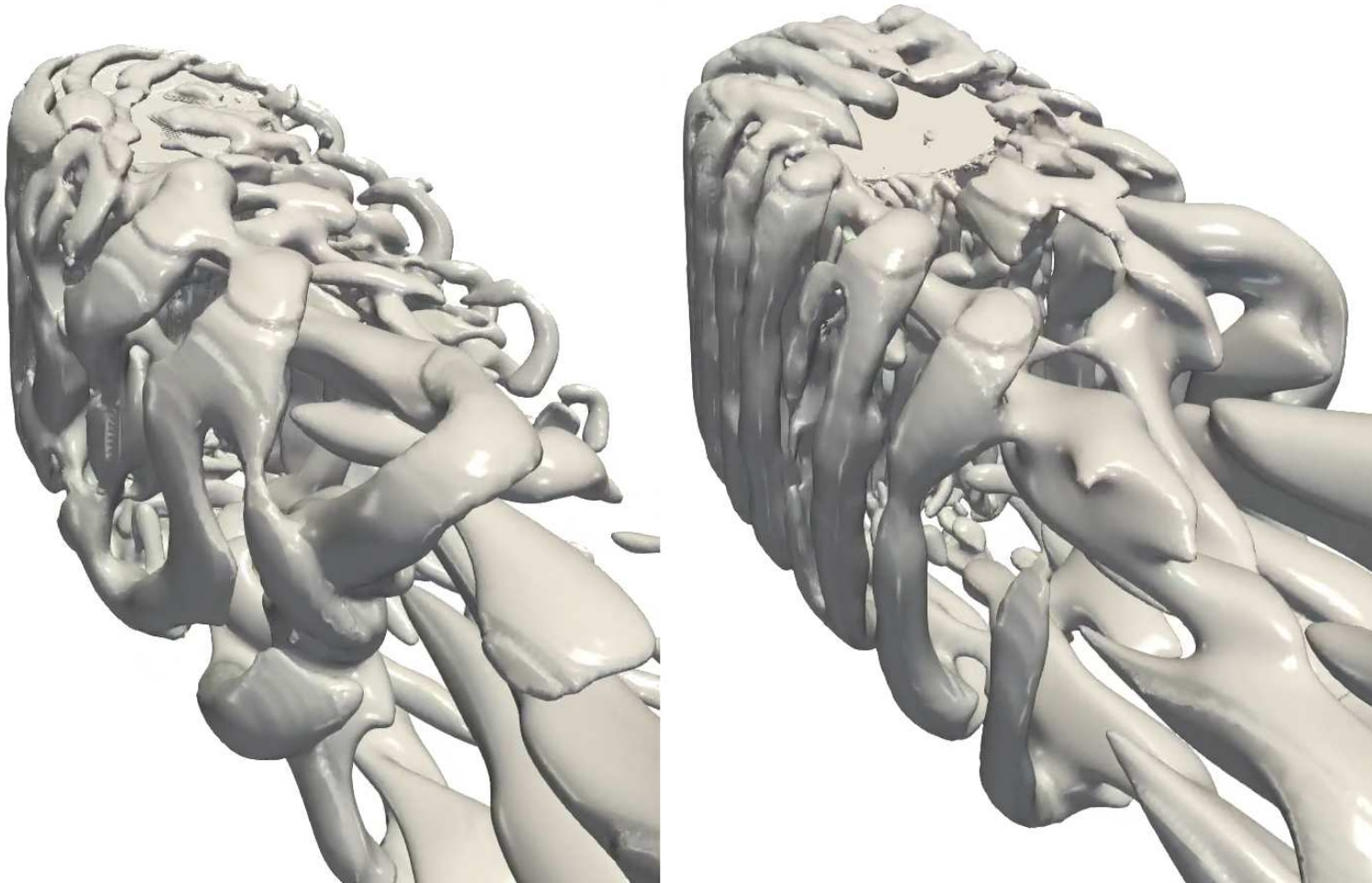

Introduction

HAWT

VAWT

Savonius

Darrieus

Combined

Banki–Michell

**Piskorz**

Unconventional

# Piskorz vs Banki–Michell

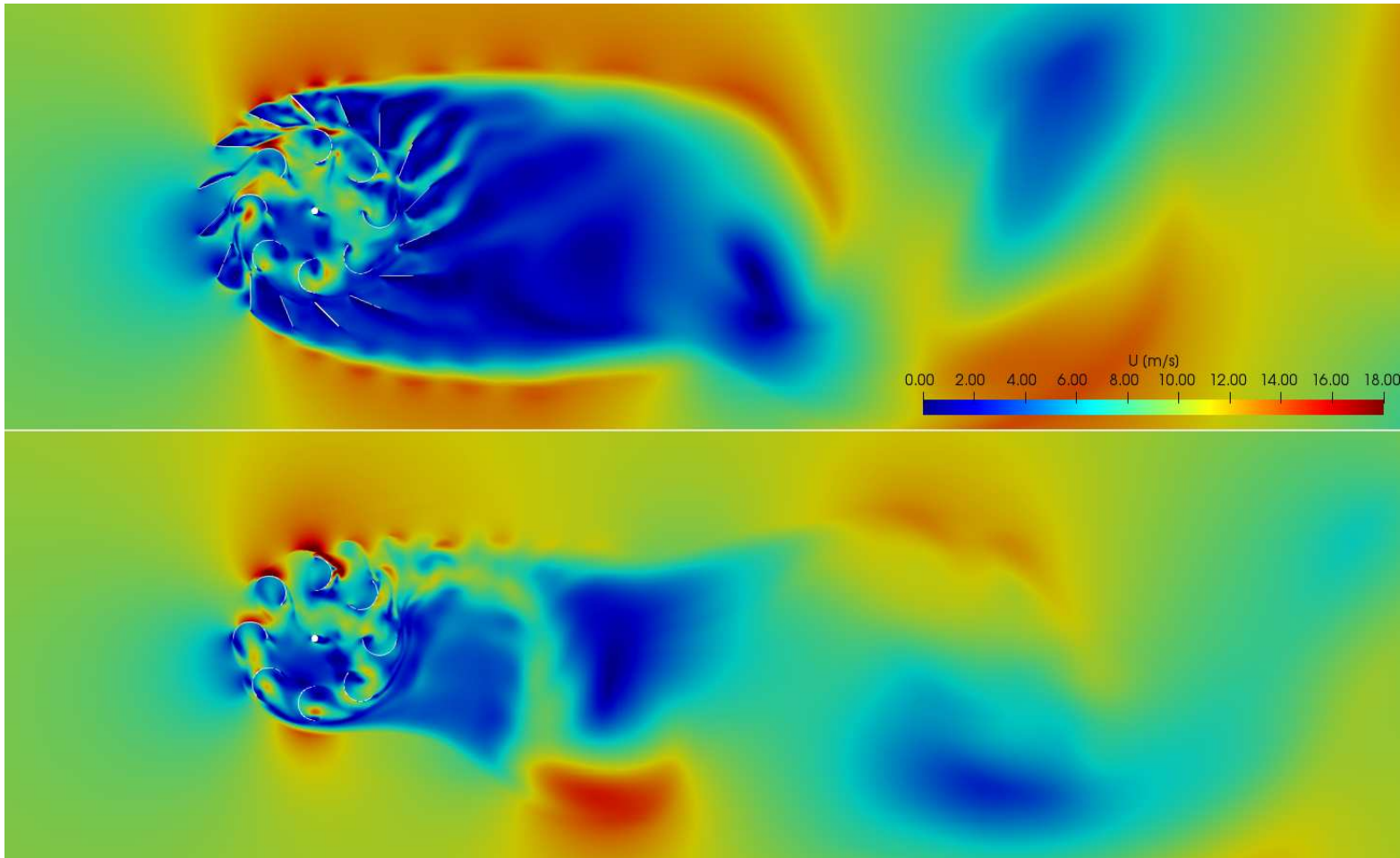

Introduction

HAWT

VAWT

Savonius

Darrieus

Combined

Banki–Michell

**Piskorz**

Unconventional



# Unconventional

Introduction

HAWT

VAWT

**Unconventional**

Counter HAWT

Counter Darrieus

Diffuser

Magnus

# Unconventional wind turbines

- Counter rotating HAWT
- Counter rotating Darrieus
- HAWT with a diffuser
- Wind turbines which utilise the Magnus effect

Introduction

HAWT

VAWT

Unconventional

Counter HAWT  
Counter Darrieus  
Diffuser  
Magnus

# Counter rotating HAWT



Introduction

HAWT

VAWT

Unconventional

**Counter HAWT**

Counter Darrieus

Diffuser

Magnus

# Counter rotating HAWT

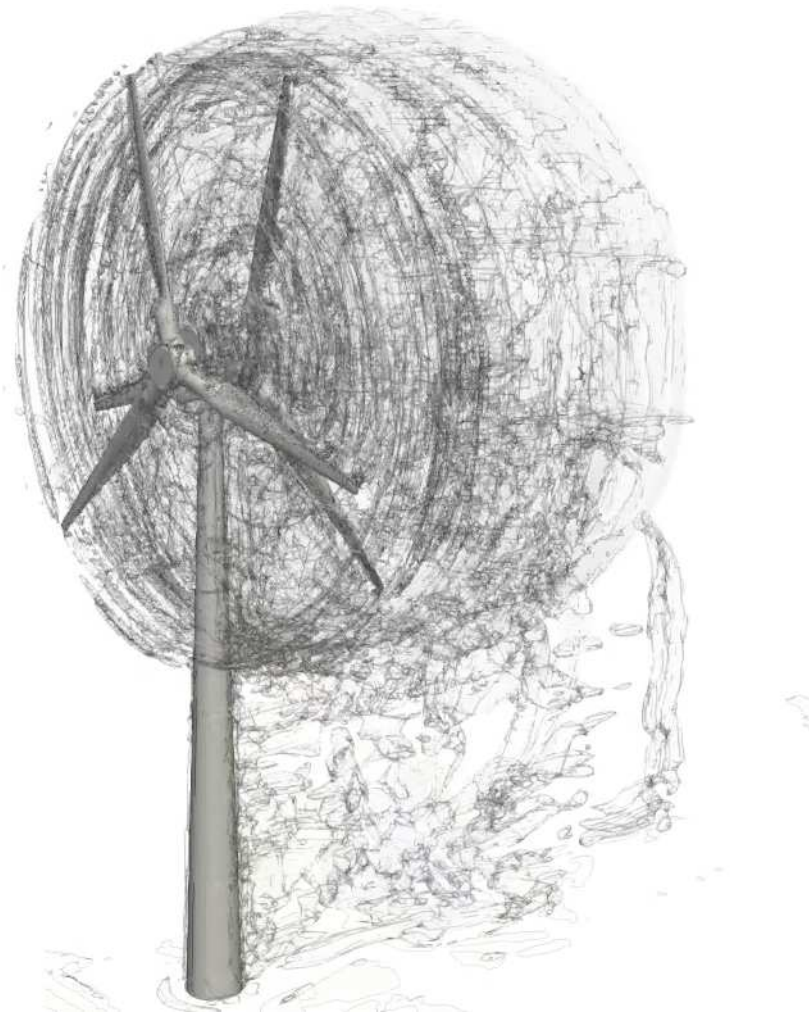

Introduction

HAWT

VAWT

Unconventional

**Counter HAWT**

Counter Darrieus

Diffuser

Magnus

# Counter rotating HAWT

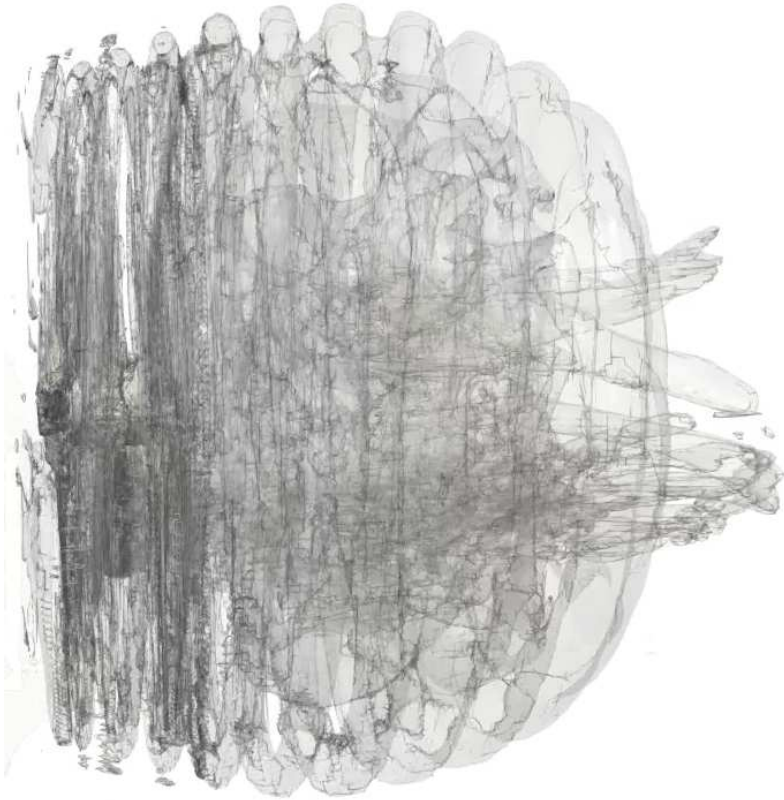

Introduction

HAWT

VAWT

Unconventional

**Counter HAWT**

Counter Darrieus

Diffuser

Magnus

# Counter rotating Darrieus

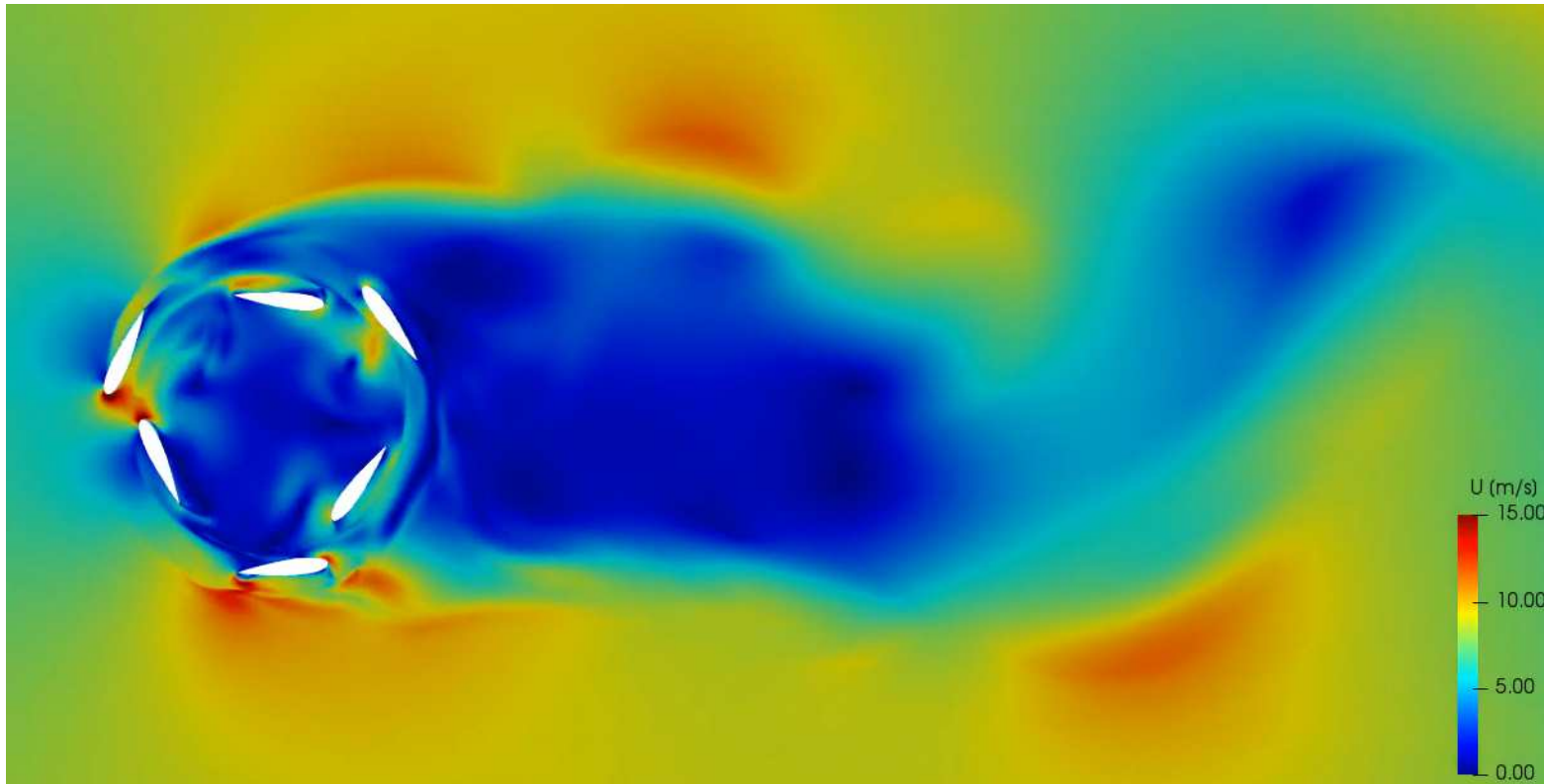

Introduction

HAWT

VAWT

Unconventional

Counter HAWT

**Counter Darrieus**

Diffuser

Magnus

# Counter rotating Darrieus vs Darrieus

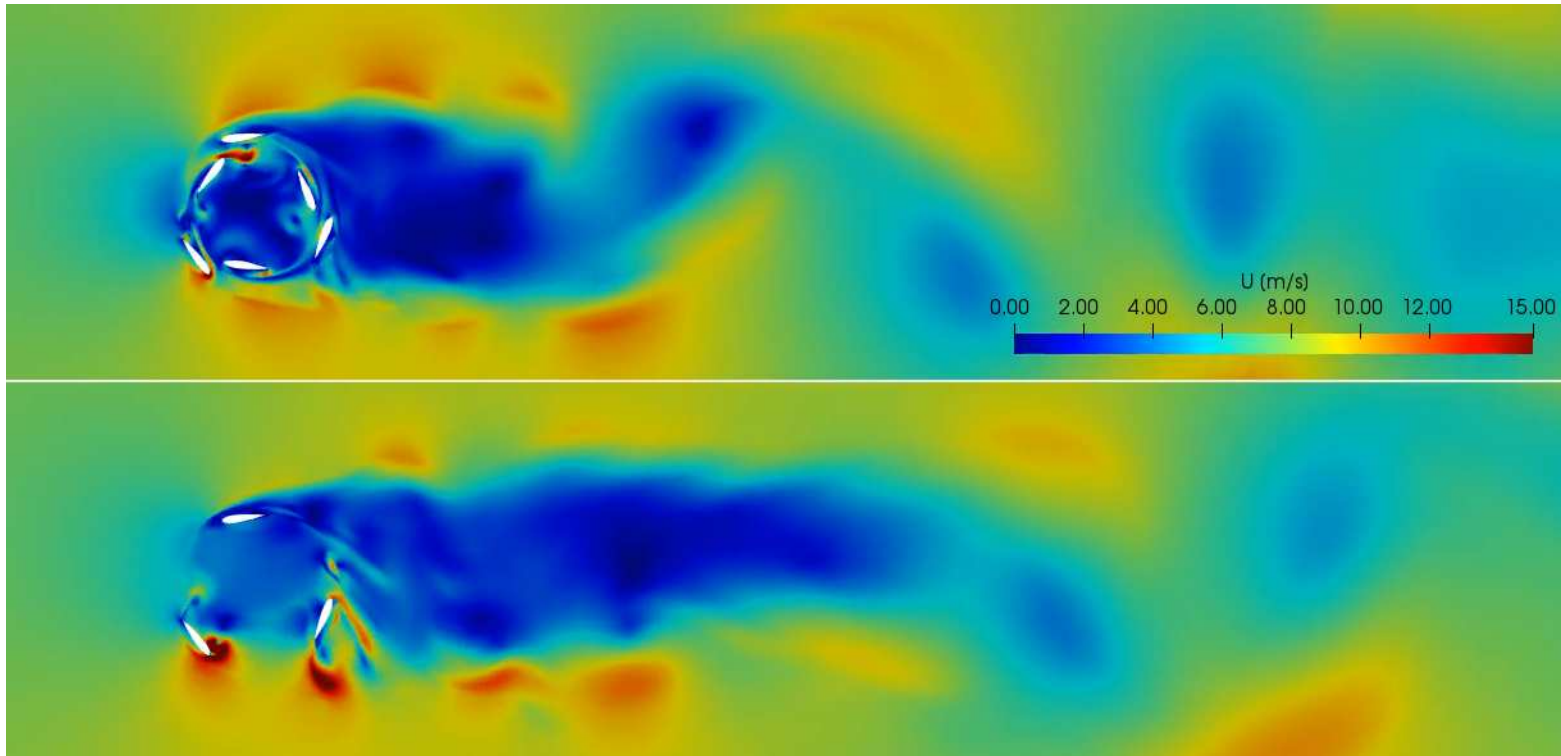

Introduction

HAWT

VAWT

Unconventional

Counter HAWT

**Counter Darrieus**

Diffuser

Magnus

# HAWT with a diffuser

Introduction

HAWT

VAWT

Unconventional

Counter HAWT

Counter Darrieus

**Diffuser**

Magnus



# Wind turbines – Magnus effect

Introduction

HAWT

VAWT

Unconventional

Counter HAWT

Counter Darrieus

Diffuser

**Magnus**